

Research Article

Sampled Data Model Control for Voltage Source Inverter

T.Yuvaraja^{1*}, Dr. M.Gopinath²

¹Research Scholar, Department of EEE, Meenakshi Academy of Higher Education and Research, India

²Professor, Department of EEE, Dr.N.G.P. Institute of Technology, Coimbatore, India

*Corresponding author

T. Yuvaraja

Email: yuvarajastr@email.com

Abstract: This paper develops a sampled-data based controller for the slow switching single-phase voltage source converter (VSC). Pulse Width Modulation variable speed drives are increasingly applied in many new industrial applications that require superior performance. Recently, developments in power electronics and semiconductor technology have lead improvements in power electronic systems. Hence, different circuit configurations namely multilevel inverters have become popular and considerable interest by researcher are given on them. There is an increasing trend of using space vector PWM (SVPWM) because of their easier digital realization and better dc bus utilization. This project focuses on step by step development SVPWM implemented on an Induction motor. The model of a three-phase a voltage source inverter is discussed based on space vector theory. Simulation results are obtained using MATLAB/Simulink environment for effectiveness of the study.

Keywords: PWM, SVPWM, VSC

INTRODUCTION

Three phase voltage-fed PWM inverters are recently showing growing popularity for multi-megawatt industrial drive applications. The main reasons for this popularity are easy sharing of large voltage between the series devices and the improvement of the harmonic quality at the output as compared to a two level inverter. In the lower end of power, GTO devices are being replaced by IGBTs because of their rapid evolution in voltage and current ratings and higher switching frequency. The Space Vector Pulse Width Modulation of a three level inverter provides the additional advantage of superior harmonic quality and larger under-modulation range that extends the modulation factor to 90.7% from the traditional value of 78.5% in Sinusoidal Pulse Width Modulation. An adjustable speed drive (ASD) is a device used to provide continuous range process speed control (as compared to discrete speed control as in gearboxes or multi-speed motors).

An ASD is capable of adjusting both speed and torque from an induction or synchronous motor. An electric ASD is an electrical system used to control motor speed. ASDs may be referred to by a variety of names, such as variable speed drives, adjustable frequency drives or variable frequency inverters. The latter two terms will only be used to refer to certain AC systems, as is often the practice, although some DC drives are also based on the principle of adjustable

frequency. In the medium voltage adjustable speed drive market, the various topologies have evolved with components, design, and reliability

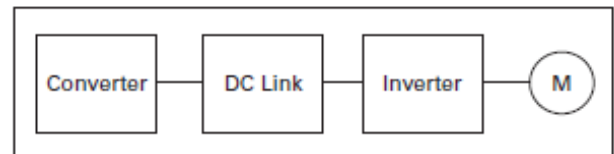

Figure.1. Source distribution

A number of Pulse width modulation (PWM) schemes are used to obtain variable voltage and frequency supply. The most widely used PWM schemes for three-phase voltage inverters are carrier-based sinusoidal PWM and space vector PWM (SVPWM). There is an increasing trend of using space vector PWM (SVPWM) because of their easier digital realization and better dc bus utilization.

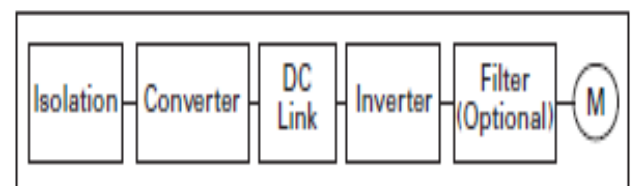

Figure.2. Optimal distribution system

The two major types of drives are known as voltage source inverter (VSI) and current source inverter (CSI). In industrial markets, the VSI design has proven to be more efficient, have higher reliability and faster dynamic response, and be capable of running motors without de-rating. VSI fully integrated design saves money with higher efficiencies, minimizing install time, eliminating interconnect power cabling costs, and reducing building floor space. Efficiencies are 97% with high power factor through all load and speed ranges. Fast dynamic response for rapid changes in motor torque and speed allow a wide range of applications. Minimum component count increases the mean time to failure (MTTF), an important number in critical uptime applications. Also, new replacement motors are not required for retrofit applications.

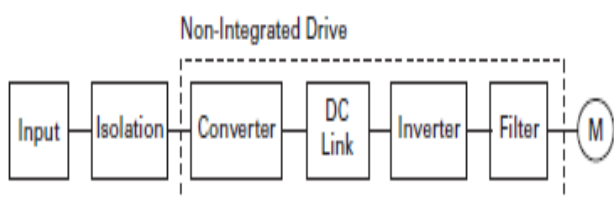

Figure.3. Non integrated distribution system

All of these factors produce a high-quality, robust Adjustable frequency drives (AFDs) are designed to allow full torque and speed control of the operating motor; how this is accomplished varies among manufacturers and the various design topologies. All medium voltage industrial AFDs consist of a converter section, a DC link, and an inverter section (see Figure 1). The converter section converts utility/line AC voltage (50/60 Hz) to DC. The DC link transmits the DC voltage to the inverter, provides ride-through capability by storing energy, and provides some isolation from the utility/line.

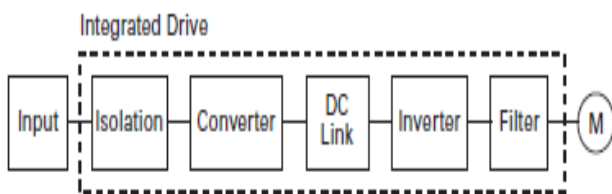

Figure.4. Integrated Distribution system

The inverter converts the DC voltage and transmits a variable voltage or current and frequency to the motor. By independently changing the current and frequency, the drive can adjust the torque produced by the motor as well as the speed at which it operates, respectively. There are more components typically required for a fully integrated system, which includes an input isolation, a transformer (or reactor), and an output filter (option), shown in Figure 2. The voltage

source inverter topology uses a diode rectifier that converts utility/line AC voltage (60 Hz) to DC. The converter is not controlled through electronic firing like the CSI drive. The DC link is parallel capacitors, which regulate the DC bus voltage ripple and store energy for the system. The inverter is composed of insulated gate bipolar transistor (IGBT) semiconductor switches. There are other alternatives to the IGBT: insulated gate commutated thyristors (IGCTs) and injection enhanced gate transistors (IEGTs). This paper will focus on the IGBT as it is used extensively in the MV VSI drives market. The IGBT switches create a PWM voltage output that regulates the voltage and frequency to the motor. The design in Figure 4 shows a neutral point clamped (NPC) three-level inverter topology. The IGBT switching devices are cascaded to achieve a 4160V system rating.

The focus of this paper is on the modelling and control of the slow switching single-phase VSC, where the term "slow switching" refers to the fact that the single-phase VSC is being switched at the fundamental frequency of the system; i.e. 60Hz. Slow switching VSCs play an important role in the emerging area of multilevel inverters, which are used in the control of high power (r 10MW) and medium voltage power systems [1], [2]. The main limitation to the slow switching VSC is the introduction of current harmonics which need to be taken into account in the control scheme. Conventional approaches use filters to remove these harmonics, but these filters introduce delay into the control and slow the dynamic response of the system. This paper demonstrates that using a sampled-data approach can result in a fast and accurate control of the slow switching VSC. Furthermore, the proposed model accounts for all the all harmonic interactions in the system, thus eliminating the need for harmonic filtering.

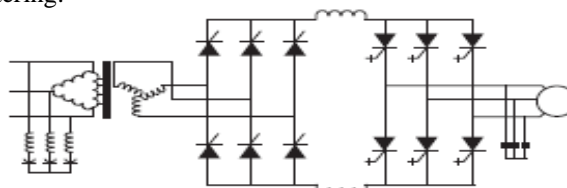

Figure.5. Thyristor Tap Changers

SAMPLED-DATA MODEL

The sampled-data approach for the modelling and control of the slow switching single-phase VSC is based on the exact modelling principles developed by Visser and Bosch in [3] for periodically switched systems, and on the exact model and control of the single-phase VSC developed by Lehn in [4].

A. Exact Modelling of the Single-Phase VSC

For the slow switching single-phase full-bridge VSC shown in Fig. 1, control is achieved through manipulating, the amplitude and the firing angle (i.e. phase shift) of the fundamental component of the ac

side terminal voltage $v_t(t)$. One control strategy that is unique to the slow switching single phase VSC and can satisfy the above criteria is a method known as voltage cancellation [5]. In voltage cancellation the single-phase VSC is switched twice per period at the zero-crossings of the input ac source voltage $v_s(t)$.

B. Latest Improvements

Microprocessor-based controllers eliminate analog, potentiometer-based adjustments. Digital control capability. Built-in Power Factor correction. Radio Frequency Interference (RFI) filters. Short Circuit Protection (automatic shutdown). Advanced circuitry to detect motor rotor position by sampling power at terminals, ASD and motor circuitry combined to keep power waveforms sinusoidal, minimizing power losses. Motor Control Centres (MCC) coupled with the ASD using real-time monitors to trace motor-drive system performance. Higher starting torques at low speeds (up to 150% running torque) up to 500 HP, in voltage source drives. Load-commutated Inverters coupled with synchronous motors.

Precise speed control in constant torque applications. Adjustable speed drives are the most efficient (98% at full load) types of drives. They are used to control the speeds of both AC and DC motors. They include variable frequency/voltage AC motor controllers for squirrel-cage motors, DC motor controllers for DC motors, eddy current clutches for AC motors (less efficient), wound-rotor motor controllers for wound-rotor AC motors (less efficient) and cyclo converters (less efficient). Pulse Width Modulation variable speed drives are increasingly applied in many new industrial applications that require superior performance. Recently, developments in power electronics and semiconductor technology have led improvements in power electronic systems. Hence, different circuit configurations namely multilevel inverters have become popular and considerable interest by researcher are given on them. Variable voltage and frequency supply to a.c drives is invariably obtained from a three-phase voltage source inverter.

Voltage Source Inverters

The main objective of static power converters is to produce an ac output waveform from a dc power supply. These are the types of waveforms required in adjustable speed drives (ASDs), uninterruptible power supplies (UPS), static var compensators, active filters, flexible ac transmission systems (FACTS), and voltage compensators, which are only a few applications. For sinusoidal ac outputs, the magnitude, frequency, and phase should be controllable. According to the type of ac output waveform, these topologies can be considered as voltage source inverters (VSIs), where the

independently controlled ac output is a voltage waveform. These structures are the most widely used because they naturally behave as voltage sources as required by many industrial applications, such as adjustable speed drives (ASDs), which are the most popular application of inverters. Similarly, these topologies can be found as current source inverters (CSIs), where the independently controlled ac output is a current waveform.

These structures are still widely used in medium-voltage industrial applications, where high-quality voltage waveforms are required. Static power converters, specifically inverters, are constructed from power switches and the ac output waveforms are therefore made up of discrete values. This leads to the generation of waveforms that feature fast transitions rather than smooth ones. For instance, the ac output voltage produced by the VSI of a standard ASD is a three-level waveform (Fig. 1c). Although this waveform is not sinusoidal as expected (Fig. 1b), its fundamental component behaves as such. This behavior should be ensured by a modulating technique that controls the amount of time and the sequence used to switch the power valves on and off. The modulating techniques most used are the carrier-based technique (e.g., sinusoidal pulse width modulation, SPWM), the space-vector (SV) technique, and the selective-harmonic-elimination (SHE) technique.

A. Single-Phase Voltage Source Inverters

Single-phase voltage source inverters (VSIs) can be found as half-bridge and full-bridge topologies. Although the power range they cover is the low one, they are widely used in power supplies, single-phase UPSs, and currently to form elaborate high-power static power topologies, such as for instance, the multicell configurations.

B. Half-Bridge VSI

Fig.6 shows the power topology of a half-bridge VSI, where two large capacitors are required to provide a neutral point N, such that each capacitor maintains a constant voltage $(V_i)/2$. Because the current harmonics injected by the operation of the inverter are low-order harmonics, a set of large capacitors (C+ and C-) is required. It is clear that both switches S+ and S- cannot be ON simultaneously because a short circuit across the dc link voltage source V_i would be produced. There are two defined (states 1 and 2) and one undefined (state 3) switch state as shown in Table In order to avoid the short circuit across the dc bus and the undefined ac output voltage condition, the modulating technique should always ensure that at any instant either the top or the bottom switch of the inverter leg is on.

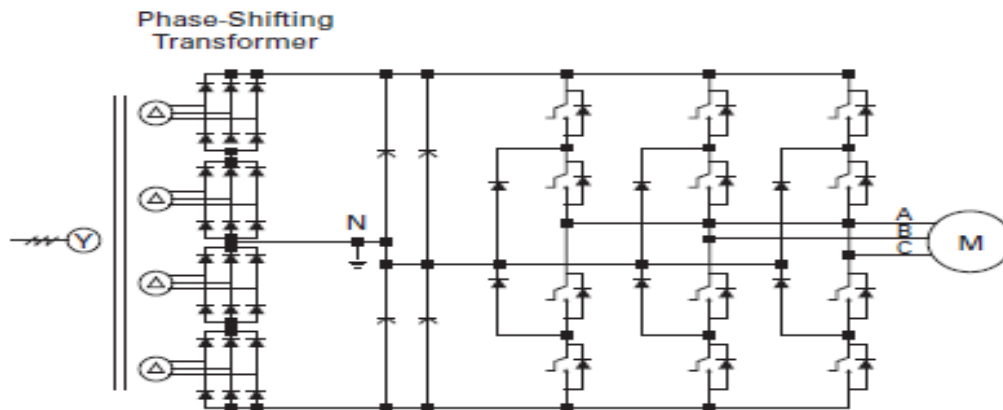

Figure.6. Full Bridge conversion circuit

C. Full-Bridge VSI

Fig.6 shows the power topology of a full-bridge VSI. This inverter is similar to the half-bridge inverter; however, a second leg provides the neutral point to the load. As expected, both switches S1+ and S1- (or S2+ and S2-) cannot be on simultaneously because a short circuit across the dc link voltage source V_i would be produced. There are four defined (states 1, 2, 3, and 4) and one undefined (state 5) switch states as shown in Table 2. The undefined condition should be avoided so as to be always capable of defining the ac output voltage. It can be observed that the ac output voltage can take values up to the dc link value V_i , which is twice that obtained with half-bridge VSI topologies. Several modulating techniques have been developed that are applicable to full bridge VSIs. Among them are the PWM (bipolar and unipolar) techniques.

D. Three Phase Voltage Source Inverters

Single-phase VSIs cover low-range power applications and three-phase VSIs cover the medium- to high-power applications. The main purpose of these topologies is to provide a three-phase voltage source, where the amplitude, phase, and frequency of the voltages should always be controllable. Although most of the applications require sinusoidal voltage waveforms (e.g., ASDs, UPSs, FACTS, VAR compensators), arbitrary voltages are also required in some emerging applications (e.g., active filters, voltage compensators). The standard three-phase VSI topology is shown in Fig. 4 and the eight valid switch states. As in single-phase VSIs, the switches of any leg of the inverter (S1 and S4, S3 and S6, or S5 and S2) cannot be switched on simultaneously because this would result in a short circuit across the dc link voltage supply.

Similarly, in order to avoid undefined states in the VSI, and thus undefined ac output line voltages, the switches of any leg of the inverter cannot be switched off simultaneously as this will result in voltages that will depend upon the respective line current polarity. Of the eight valid states, two of them (7 and 8 in Table 3)

produce zero ac line voltages. In this case, the ac line currents freewheel through either the upper or lower components. The remaining states (1 to 6 in Table 3) produce non-zero ac output voltages. In order to generate a given voltage waveform, the inverter moves from one state to another. Thus the resulting ac output line voltages consist of discrete values of voltages that are V_i , 0, and $-V_i$ for the topology shown in Fig. 4. The selection of the states in order to generate the given waveform is done by the modulating technique that should ensure the use of only the valid states.

Pulse Width Modulation in Inverters

Output voltage from an inverter can also be adjusted by exercising a control within the inverter itself. The most efficient method of doing this is by pulse-width modulation control used within an inverter. In this method, a fixed dc input voltage is given to the inverter and a controlled ac output voltage is obtained by adjusting the on and off periods of the inverter components. This is the most popular method of controlling the output voltage and this method is termed as Pulse-Width Modulation (PWM) Control. The advantages possessed by PWM techniques are as under. The output voltage control with this method can be obtained without any additional components. With the method, lower order harmonics can be eliminated or minimized along with its output voltage control. As higher order harmonics can be filtered easily, the filtering requirements are minimized. With the method, lower order harmonics can be eliminated or minimized along with its output voltage control. As higher order harmonics can be filtered easily, the filtering requirements are minimized. The main disadvantage of this method is that SCRs are expensive as they must possess low turn-on and turn-off times. PWM inverters are quite popular in industrial applications. PWM techniques are characterized by constant amplitude pulses. The width of these pulses is however modulated to obtain inverter output voltage control and to reduce its harmonic content. The different PWM techniques are as under, Single-pulse modulation, Multiple pulse modulation Sinusoidal pulse width modulation(Carrier

based Pulse Width Modulation Technique) Here we studied about Carrier based Pulse Width Modulation for open loop control of three-

SPWM for Three Phase VSI

This is an extension of the one introduced for single-phase VSIs. In this case and in order to produce 120° out-of-phase load voltages, three modulating signals that are 120° out of phase are used. Fig. 7 shows the ideal waveforms of three-phase VSI SPWM. In order to use a single carrier signal and preserve the features of the PWM technique, the normalized carrier frequency *mf* should be an odd multiple of 3. Thus, all phase voltages (*vaN*, *vbN*, and *vcN*) are identical but 120° out of phase without even harmonics; moreover, harmonics at frequencies a multiple of 3 are identical in amplitude and phase in all phases. For instance, if the ninth harmonic in phase *aN*

A. Space Vector Pulse Width Modulation for 3-phase VSI

The topology of a three-leg voltage source inverter is shown in Fig. 9. Because of the constraint that the input lines must never be shorted and the output current must always be continuous a voltage source inverter can assume only eight distinct topologies. These topologies are shown on Fig. 10. Six out of these eight topologies produce a nonzero output voltage and are known as non-zero switching states and the

remaining two topologies produce zero output voltage and are known as zero switching states. Space vector modulation (SVM) for three-leg VSI is based on the representation of the three phase quantities as vectors in a two-dimensional () plane. This is illustrated here for the sake of completeness. Considering which is repeated in the line voltages *Vab*, *Vbc*, and *Vca* are given by All SVM schemes and most of the other PWM algorithms use Eqns. (14) and (15) for the output voltage synthesis. The modulation algorithms that use non-adjacent SSV's have been shown to produce higher THD and/or switching losses and are not analyzed here, although some of them, e.g. hysteresis, can be very simple to implement and can provide faster transient response. The duty cycles *d1*, *d2*, and *d0*, are uniquely determined from Fig. 2.7, and Eqns. (14) and (15), the only difference between PWM schemes that use adjacent vectors is the choice of the zero vector(s) and the sequence in which the vectors are applied within the switching cycle. Implementing SVPWM

The SVPWM can be implemented by using wither sector selection algorithm or by using a carrier based space vector algorithm. The types of SVPWM implementations are, Sector selection based space vector modulation, Reduced switching Space vector modulation, Carrier based space vector modulation, Reduced switching carrier based space vector modulation.

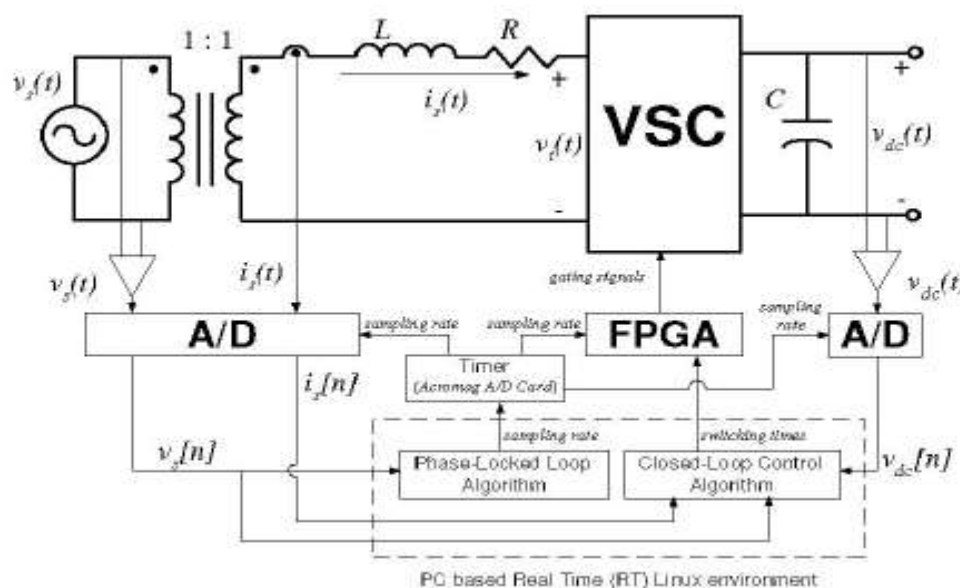

Figure.7. Full control circuit of VSC conversion

The system parameters of the single-phase VSC used in the power lab to implement the two digital control strategies are listed. Note that in all the simulations and implementations, the dc side is not connected to a load so the load current, *i1*, is zero and the dc side resistance is approximated to be infinitely

large. The steady state operating points chosen for the closed-loop full-state feedback control are all taken at where the phase shift, ϕ , equals 0. From Fig. 5 it is clear that this case covers all the necessary operating range of the single-phase VSC in terms of both ac side current and dc side voltage, and it is not necessary to

complicate calculations by introducing a phase. The purpose of the feed forward function g is to allow the system to track a specific set of reference signals. In the context of the overall control, the feed forward function generates the correct reference switching times $-ref$ which should ideally drive the system to the desired reference states ref even with no feedback present. The function g is clearly the steady state relationship between the switching times and the states of the system, which is the inverse of equation (23). While matrices E and F are functions of the switching times, a simple inverse relation for equation (23) does not exist. Therefore to derive g , mathematical tools such as MATLAB are required.

CONCLUSION

This paper presents a VSC modelling and control approach suitable for slow switching applications. In contrast to averaged models that neglect the influence of converter harmonics, the proposed approach accurately represents all ac/dc side harmonic interactions. This eliminates the need for low bandwidth filtering of feedback control signals, allowing the design of a high bandwidth sampled-data controller. Experimental results demonstrate that both the ac side current and the dc side voltage settle into steady state within 1 cycle after a transient. Although the proposed control algorithm requires intensive computations to be performed at the design state, the resulting sampled-data controller is computationally efficient and easy to implement. The Modulation Index is higher for SVPWM as compared to SPWM. The output voltage is about 15% more in case of SVPWM as compared to SPWM. The current and torque harmonics produced are much less in case of SVPWM. However despite all the above mentioned advantages that SVPWM enjoys over SPWM, SVPWM algorithm used in three-level inverters is more complex because of large number of inverter switching states.

REFERENCES

1. Rodriguez J, Jih-Sheng Lai, Peng FZ; Multilevel inverters: A survey of topologies, controls, and applications", IEEE Trans. On Industrial Electronics, 2002;49: 724-738.
2. Haque MT; Single-phase pq theory,PESC, 2002; 4:1815-1820.
3. Visser HR, van den Bosch P; Modelling of periodically switching networks", PESC. 1999: 63-73.
4. Lehn PW; Modelling and control of switched circuits for high power applications. University of Toronto, PhD Thesis, 1999, chapter 2.
5. Mohan N, Undeland TM, Robbins WP; Power Electronics: Converters, Applications and Design Second Edition. John Wiley and Sons Inc., Toronto, 1995, chapter 8.
6. Perkins BK; Dynamic Modeling of an Inverter-Based Compensator", PESC, 1999; 2: 727-732.

7. Holtz J; Pulse width modulation for electronic power conversion. Proc. IEEE, 1994; 82:1194-1214.
8. Ogasawara O, Akagi H, Nabel A; A novel PWM scheme of voltage source inverters based on space vector theory," in Proc. EPE European Conf. Power Electronics and Applications, 1989: 1197-1202.
9. Depenbrock M; Pulsewidth control of a 3-phase inverter with nonsinusoidal phase voltages," in Proc. IEEE-IAS Int. Semiconductor Power Conversion Conf., Orlando, FL, 1975; 389-398.
10. Houldsworth JA, Grant DA; The use of harmonic distortion to increase the output voltage of a three-phase PWM inverter," IEEE Trans. Ind. Applicat., 1984; 20:1224- 1228.
11. Modern Power Electronics and AC Drives, by Bimal K. Bose. Prentice Hall Publishers, 2001
12. Power Electronics by Dr. P.S. Bimbhra. Khanna Publishers, New Delhi, 2003. 3rd Edition.
13. A Power Electronics Handbook by M.H. Rashid. Academic Press 2001.