

Research Article

A Microcontroller Based Security System

Nathan David^{1*}, Genesis Ajah²

¹Department of Electronic Engineering, Faculty of Engineering, University of Nigeria, Nsukka.

²Department of Electrical Engineering, Faculty of Engineering, University of Nigeria, Nsukka.

***Corresponding author**

Nathan David

Email: nathan.david@unn.edu.ng

Abstract: According to the popular philosopher - Abraham Maslow, security is the second most basic need of man. There is need to protect life and property, in order to do this a security system must be developed. The purpose of this project is to develop a highly efficient and affordable security system with an industrial complex as a case study, which would take necessary countermeasures against possible security risks to man and property. These countermeasures are in three layers. The first layer is protection against fire outbreaks through a fire detector comprising a smoke detector and a temperature sensor. The second layer is intrusion detection which monitors and prevents unauthorized access. The last layer is live video monitoring and analysis employing the use of IP security cameras. In addition, Automated Fingerprint Identification System (AFIS) ensures that only registered staff are allowed access into the industrial complex at any point in time and a door way counter determines the number of people present in the building at any given time. More so, this system is completely digital and customizable, incorporating Liquid Crystal Display (LCD) and rich Graphic User Interfaces (GUIs).

Keywords: Automated Fingerprint Identification System, Video Surveillance, Web Portal, Control Unit.

INTRODUCTION

Security is the degree of protection against danger, damage, loss and crime. Security as a form of protection includes structures and processes that provide or improve security as a condition. Security systems, hence, monitor the state of a property and access of persons unto and around the property. In the present day, security systems play an important role in the protection of lives and investment and hence integrate the necessary intelligence required to alert a property owner should the integrity of the property be jeopardized, or should imminent danger to any authorized person on the property be detected. This is achieved by the incorporation of various subsystems into the security system with a single control unit. This work focuses on the general subsystems incorporated into the security system of an industrial complex which for instance could be a large office building with a possible production plant. The various units of the security system are discussed and their basic functions elaborated providing information on the design of the security system, as well as the implementation techniques employed. In conclusion the various ways in which research may further enhance the capabilities of this system are suggested.

OVERVIEW OF THE SECURITY SYSTEM

The basic block diagram of the security system developed is shown in Figure 1. Registration of staff basic profile and capture of fingerprint biometric data is carried out via the registration module. The update module serves to modify information of already registered staff should the need arise.

Authentication is carried out via AFIS. Research has shown that a fire outbreak is normally associated with an increase in temperature, or the presence of smoke, or both. For this reason, a smoke detector is incorporated, and its sole aim is to detect the presence of smoke particles within the building and alert the property owner. It is integrated with a temperature sensor which senses the environment temperature conditions, and is capable of alerting the property owner should room temperature escalate above normal. For record and security purposes, the number of people within a building should be ascertained and hence a door way counter is incorporated. The door way counter is able to count the number of people entering and leaving the building via entrance and exit points. An intrusion detector, designed to operate at after-office-hours, is used to detect illegal access into the building within this time. In modern times, surveillance remains the best means for monitoring. The internet is

also one of the fastest means of communication. This work exploits the features offered by both surveillance and internet communication [1].

In order to achieve this, a web portal is designed with a one-factor authentication system (username and password) which is used to grant users

access. Online monitoring of the property is thus possible by the property owner from virtually any part of the world. Some other subsystems integrated into this security system include a water level indicator, whose function is to monitor the level of water within the company tank at all times, and alert the property owner should water be full or empty.

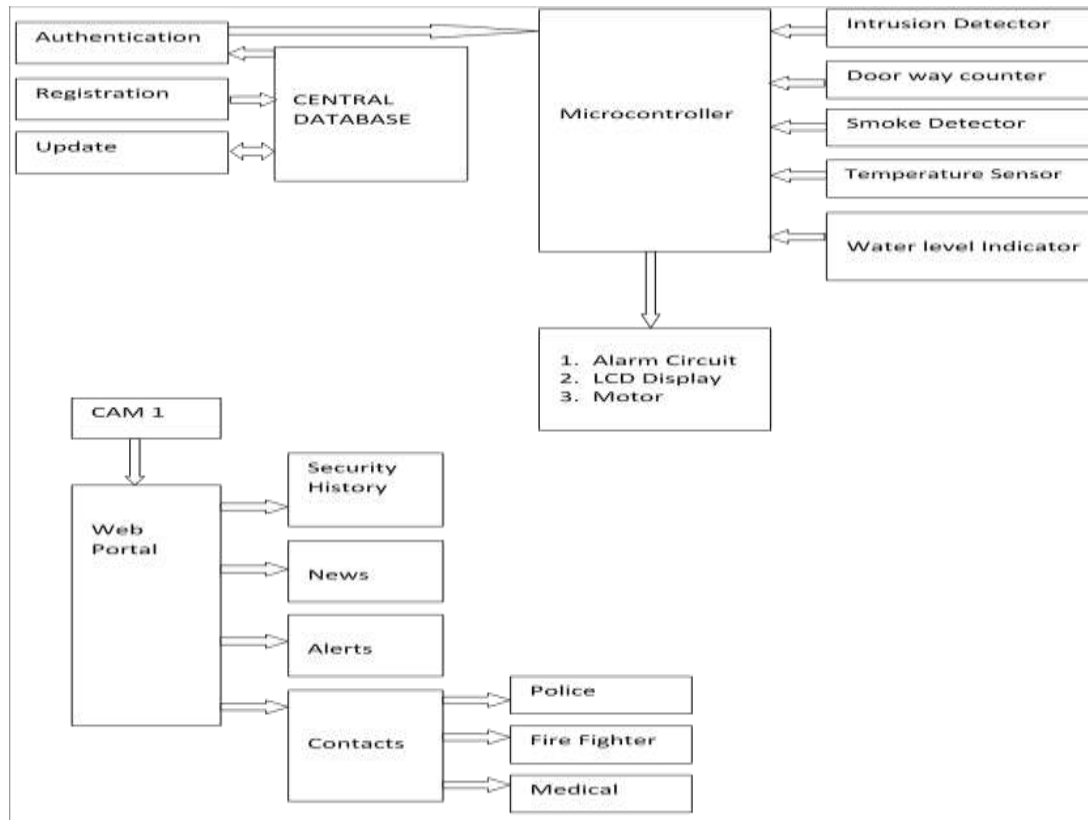

Fig-1: Block diagram of the security system

DESIGN AND IMPLEMENTATION

The methods used at arriving at the final design of this system and the components employed revolve around a compromise between effectiveness, compactness, cost and efficiency. The main aim of any security system is to provide effective monitoring, access and reactive services at an affordable price. This work is thus a scaled down model or prototype of a security system for an industrial complex. There are two major modules in the design: the hardware module and the software module. Each of these modules has a defined function and is further divided into sub-modules which work together to achieve the specified goal.

SOFTWARE MODULE

User Registration and Update

Staff basic profile and fingerprint biometric data is captured on this section of the software. User information can be updated as need be but the biometric data cannot be updated since this data is always the same for everybody.

Automated Fingerprint Identification System (AFIS)

This part of the software ensures that only registered users are granted access to the industrial complex. AFIS executes a 1 to n search on the database of registered users to find a match. This search was designed with a well-tested algorithm to reduce the time for search while ensuring that only registered users will have a match.

Web Portal

A web portal is a web site that functions as a point of access to information in the World Wide Web. A portal presents information from diverse sources in a unified way. Apart from the standard search engine feature, web portals offer other services such as e-mail, news, information, databases and entertainment. Portals provide a way for enterprises to provide a consistent look and feel with access control and procedures for multiple applications and databases, which otherwise would have been different entities altogether. The primary purpose of the web portal developed for this project is to enable remote

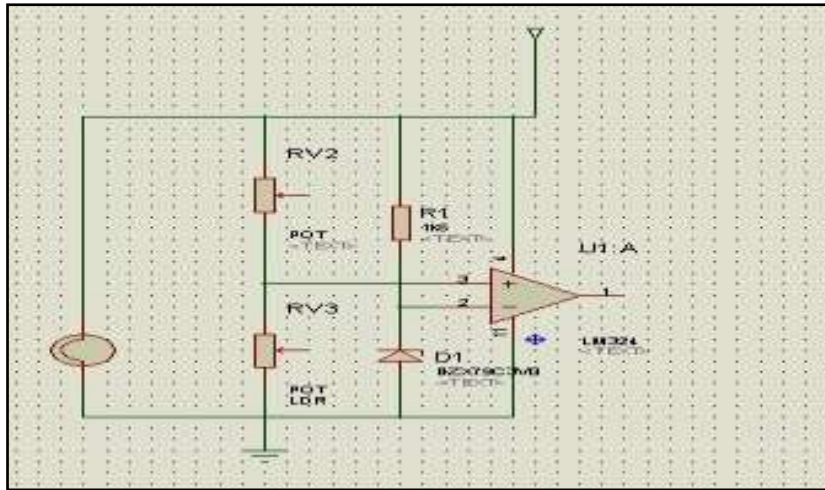

Fig-4: Smoke detector circuit diagram

Door way counter and intruder detector

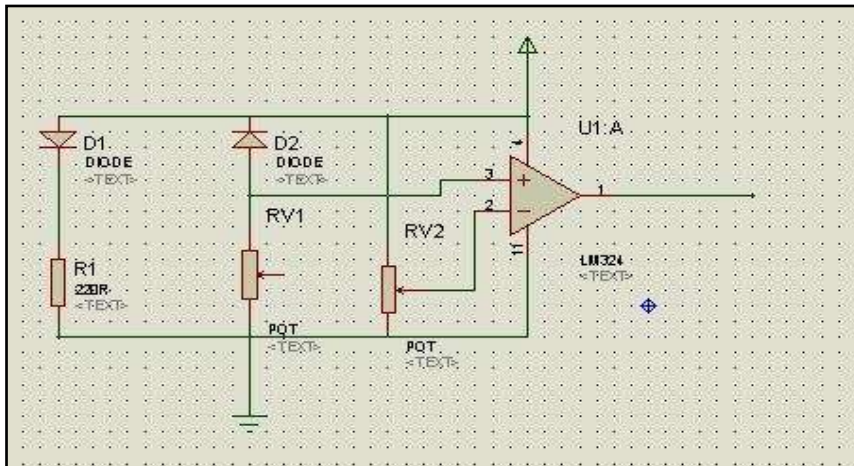

Fig-2: Door way counter circuit diagram

It is necessary to ascertain the number of staff, as well as visitors within the industrial complex at a particular time. The door way counter senses entrance into and exit from the building by individuals, and displays this information via an LCD. The intrusion detector is used to detect illegal or unauthorized entrance into the industrial complex, the circuit is

shown in figure 6. Both sensors have similar circuit geometry, and employ the use of an IR receiver and IR transmitter to form an optocoupler with a continuous beam. An optocoupler is an electronic device designed to transfer electrical signals by utilizing light waves to provide coupling with electrical isolation between its input and output.

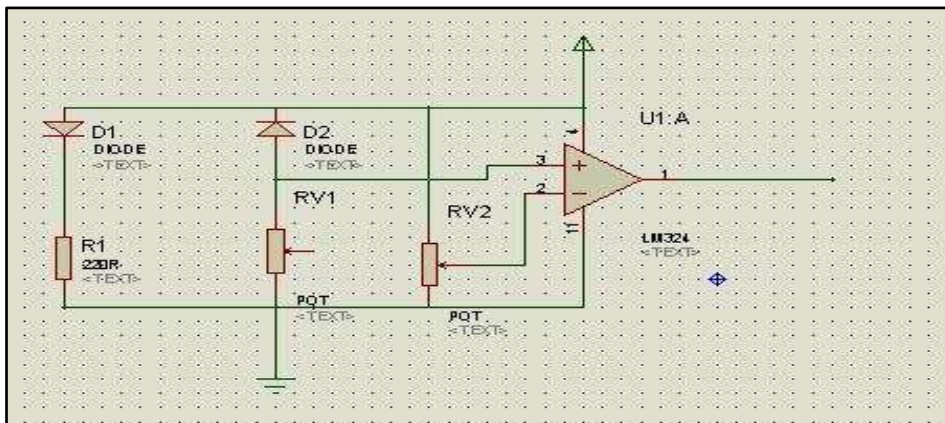

Fig-3: Circuit diagram of the intrusion unit

In the case of the door way counter, a break of the continuous beam triggers a counter which increments if an entrance is made, or decrements if an exit is made, whereas in the case of the intrusion detector, a break of the continuous beam triggers an alarm. The IR receiver and transmitter are placed at opposing sides of the entrance and exit doorways.

Video Surveillance

Surveillance refers to is the monitoring of the behavior, activities, or other changing information, usually of people. The surveillance system developed for this security systems makes use of IP cameras. The IP camera provides video recording and rotary vision which allows it to view different angles of the building.

Automated Fingerprint Identification System (AFIS)

A finger print scanner is used to capture the fingerprint biometric data of staff during the registration process, as well as during authentication at entrance and exit points. The fingerprint scanner used is Digital Persona fingerprint scanner[3]. DigitalPersona’s

fingerprint authentication provides a natural extension to security systems and applications. The U. and U4000B Reader is a USB finger print reader designed for use with Digital Persona’s enterprise software applications and developer tools. The procedure of operation is relatively simple. The user places his/her finger on the glowing reader window, and the reader quickly and automatically scans the fingerprint. On-board electronics calibrate the reader and encrypt the scanned data before sending it over the USB interface [4]. Digital Persona readers utilize optical fingerprint scanning technology to achieve excellent image quality, a large capture area and superior reliability.

The Water Level Indicator

This unit indicates the level of water at four levels; when the tank is full, empty and at two intermediate levels. It is designed in such a way that the alarm is triggered when the water gets to the top of the tank (full) and the bottom level of the tank (empty). The circuit diagram of the water level detection unit is shown in figure 7.

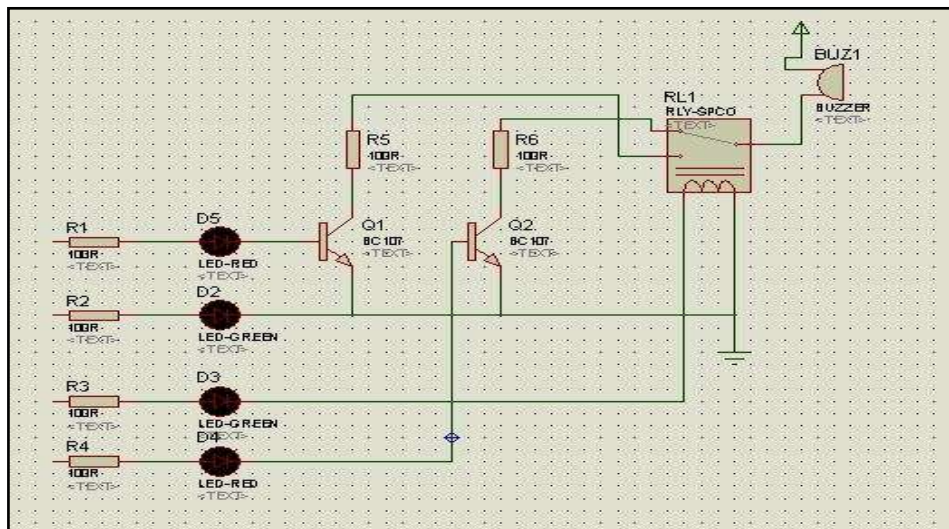

Fig-4: Circuit diagram of the water level detection unit

The Control Unit

A control unit in general is a central (or sometimes distributed but clearly distinguishable) part of a machinery that controls its operation, provided that the machinery is complex and organized enough to contain any such unit. The microcontroller used in the design of the control unit for project is Atmel AT89C52 and it belongs to the 8051 family of microcontrollers[5]. The AT89C52 is a low-power, high-performance CMOS 8-bit microcontroller with 8Kbytes of in-system programmable Flash memory. The device is manufactured using Atmel’s high-density non-volatile memory technology and is compatible with the industry-Standard 80C51 instruction set and pin-out. The on-chip Flash allows the program memory to be reprogrammed in-system or by a conventional non-

volatile memory programmer. Figure 8 shows the pin-out diagram of AT89S52.

CONCLUSION AND RECOMMENDATION

Due to the increasing need to implement high security systems in today’s technologically advanced world in order to secure valuable information from illegal access, research and developments are currently taking place in the field of biometrics and monitoring, in order to increase its efficiency. This project is upgradeable. Recommendations for the future include:

- Use of an alternate power source such as solar power or UPS, that would serve as a backup to ensure that all functional units are always in operation at all times.

- Provision of more security subsystems such as automatic lights, glass break detectors, voice recognition systems etc.
- Inclusion of emergency module, to trigger an alarm and call an ambulance in the case of an accident in the industry.

REFERENCES

1. Ajah G, David N, Abioye AO; Web Based Security System. Scholars Journal of Engineering and Technology, 2013; 1(3):112-116
2. Rangan CS, Sarma GR, Mani VSV; Instrumentation: devices and systems. Tata McGraw-Hill. 1983.
3. Maio D, Maltino D, Jain AK, Prabhakar S; Handbook of Fingerprint Recognition. Springer Verlag, 2003.
4. Abioye AO, David N; Computer Interfacing Through the USB Port(Building a USB Device), International Journal of Engineering Research & Technology, 2013; 2(9).
5. Axelson, Jan. The Microcontroller Idea Book. Madison: Lakeview Research, 1997.