

Research Article

Improvement Design of Vertically-telescopic Substructure of ZJ30 Rig based on the theory of finite element

Zhang Xiaoguang*, Xu Baorui, Yang Jingyuan

College of mechanical science and engineering, Northeast Petroleum University, Daqing 163318, China

***Corresponding author**

Zhang Xiaoguang

Email: xiaoguang8424@126.com

Abstract: According to the actual structure and stress state of the ZJ30 rig derrick and substructure, the beam element model of the derrick and the entity model of the substructure for finite element analysis were established in the article. Considering three most dangerous working conditions, the derrick rising, maximum hook load and casing installation, the load on the substructure was calculated by the software ANSYS ,a finite element analysis software the force and deformation on the part of the substructure were analyzed. The weak parts with the big stress and deformation were redesigned and recalculated based on the above to ensure the safety of the substructure in operation.

Keywords: the substructure of rig, structure, finite element

INTRODUCTION

The substructure is an important part, the foundation of support of drilling rig. The main components of rig, such as derrick (and the crane, travel car hook, swivel, etc.), rotary table, draw works, power transmission equipment, and wellhead mechanized tools and related assistant drilling equipment, are installed on a substructure, and rely on the substructure to maintain their relative position and mounting dimensions. The substructure also provides space for drilling strings and operation place for drilling workers. At the same time the substructure is under various static and dynamic loads in transport, installation and operation process. In order to ensure the substructure at the life expectancy under the design loads safely, the occurrence of failure strength and greater degree of deformation or instability, resulting in equipment damage and personal injury, the were accurate structural analysis, in order to find the structure of weak position, is very necessary.

The ZJ30/1700DB rig

ZJ30/1700DB rig is AC-DC-AC frequency conversion electric drive and digital control drilling machine, for the exploration and development of oil and gas wells and 3000m deep well drilling. JJ170/33-KS1 derrick is one of the important parts of the ZJ30/1700DB rig. JJ170/33-KS1 derrick is installed in DZ170/5-SJ vertically-telescopic substructure with the use of drilling equipments, for placing a crane, suspension winding system, placing drilling strings, casing installation, processing downhole accidents and so on. The substructure DZ170/5-SJ is vertically-telescopic, and was used with the ZJ30/1700DB rig,

for placing rig derrick, drawworks, rotary table, placing the drilling strings and drilling tools, and provides the drilling operation places and wellhead installation space. The substructure bears drilling work load, derrick rising load, equipment of gravity load, and transmits these loads to the foundation and ground.

The load analysis of ZJ30/1700DB rig derrick and substructure

The load of the substructure is relative to its working conditions. Three conditions were calculated and discussed in the article:

- ①derrick rising(case I);
- ②maximum hook load (case II);
- ③casing installation (mode III);

Derrick rising is the conditions of integral lifting derrick starting from a horizontal position. Maximum hook load is the maximum hook load on the derrick rig, and the condition of the drilling strings box full of drilling strings. The maximum hook load usually appears in drilling operations of the maximum depth or unfreezing. The casing installation is that the casing is clamped on the rotary table and the drilling strings box is full of drilling strings when casing. In order to facilitate the calculation, the following several load modes were considered:

Mode 1: The gravity load

The gravity load included the gravity of the derrick, the gravity of the hoisting system, the gravity of the substructure, the gravity of the turntable, the gravity of the winch.

Mode 2: The derrick load

The derrick load was considered according to the maximum load of rig hook on the derrick, the maximum load for the rig hook was

$$Q_{\max} = k_{\text{储}} q_{\text{柱}} L_{\max}$$

Mode 3: The turntable load

The turntable load was considered according to the maximum load of rig hook on the turntable.

Mode 4: The drilling strings load

The drilling strings load was that the force was loaded by the drilling strings load on the derrick and substructure. The drilling strings load was calculated by the following formula:

$$Q_{\text{立根}} = q_{\text{柱}} L_{\max}$$

Model 5:

The rising load, according to the derrick lifters (drawworks and hoisting system rise, or hydraulic), the specific structure and size, and according to the gravity load of the derrick and the traveling system, was calculated with the static balance.

According to the characteristics of the three conditions, the load calculation of various working conditions as follows:

Condition I:

Operating mode 1+ mode 5; Condition II: operating mode 1+ mode 2+ mode 4; Condition III: mode 1+ mode 3+ mode 4.

The establishment of finite element model of ZJ30/1700DB derrick and the calculation of the force loaded on the substructure

The finite element model of the derrick

The derrick height was 33000mm and generally divided into upper and lower sections, 17500mm and 19000mm, in the middle of the overlapping 3500mm, the legs of derrick fallen to the ground, the front braced and maintained the stability.

The derrick was welded by steel of all kinds of different sections and the cross section datas are as follows:

Thigh: 145mm *75mm*8mm; bar has two: 145mm *75mm *8mm and 140mm* 80mm* 6mm; Inclined bars also have two: 100mm *100mm* 6mm and 100mm *70mm*6mm; herringbone frame section is round tube: D=180mm and wall of the thickness was 10mm; the herringbone frame brace for connection was round tube: D=90mm, wall thickness is 5mm.

The main material of the derrick is Q235, elastic modulus $E=2.1e11$, Poisson's ratio $\mu =0.3$, the density was 7800 kg/m^3 . According to the characteristic of the derrick and the finite element analysis software ANSYS, The K type derrick is discretized into beam elements. The derrick is a rigid frame structure, the simplified beam element model is feasible for finite element calculation. According to the above datas and combined with the derrick assembly drawings the finite element model was built as shown in figure 1. Fig1 (a) was the extended derrick model, fig1 (b) was the retracted derrick model when hoisting. There were 192 nodes and 444 elements in the whole model. For the convenience of subsequent discussions, the global coordinate system derrick in an upright position and a horizontal state and the node number at the bottom were given, as shown in Figure 2.

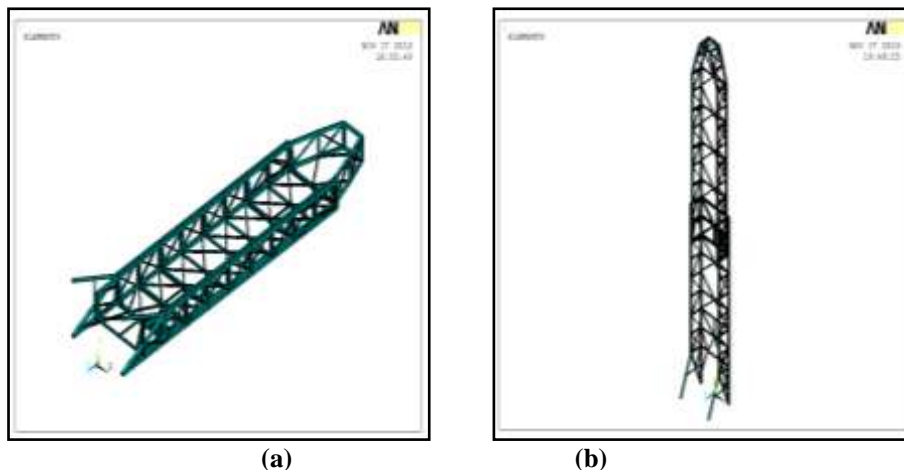

Fig-1: The model of the derrick

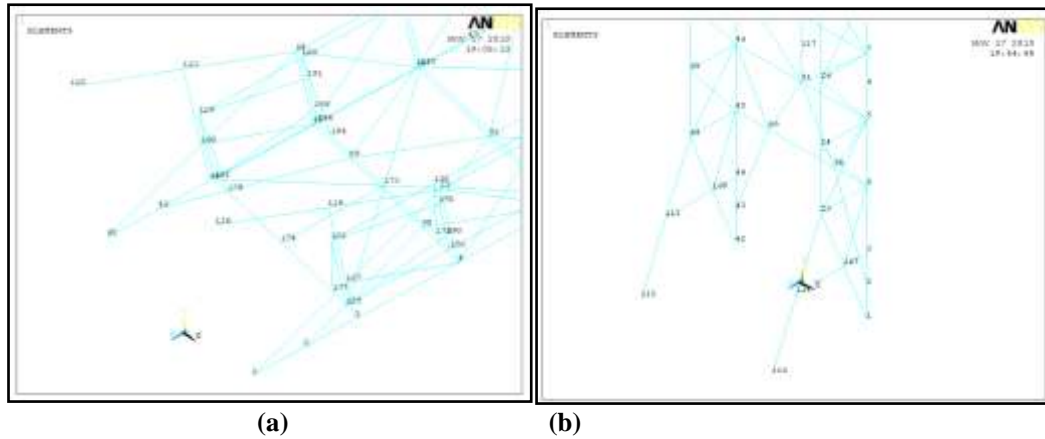

Fig-2: The global coordinate system and the node number sketch at the derrick bottom

THE CALCULATION OF THE FORCES LOADED ON THE SUBSTRUCTURE BY THE DERRICK UNDER THREE CONDITIONS

The calculation of the force loaded on the substructure by the derrick under derrick rising

When the derrick rised, the upper section was shown in Fig 1 (a) and the derrick was in the horizontal state. At the bottom node 1 and 42 were applied by UX,UY, UZ, ROTY, ROTZ direction constraints

(derrick legs only rotate around the X shaft), node 4 and 45 were applied by UY direction constraint (the movement of the derrick was limited by lifting hydraulic cylinder in Y direction). The load of the derrick included: the gravity of the derrick was 19.85t, the gravity of the crane was 3.5t, the gravity of hook was 4t, the gravity of two taiwan was 1t. The loaded derrick model was shown in Fig 3.

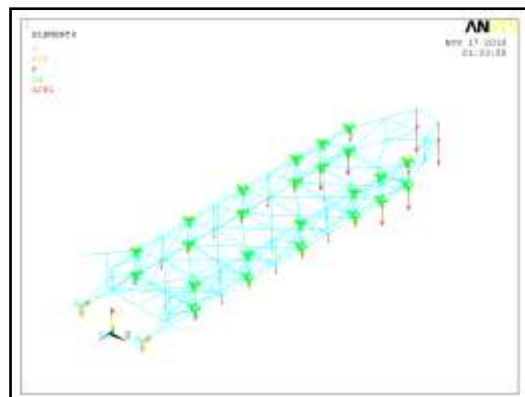

Fig-3: The calculation model under derrick rising

The derrick stress and displacement figures were shown in figure 4 and 5 after solving.

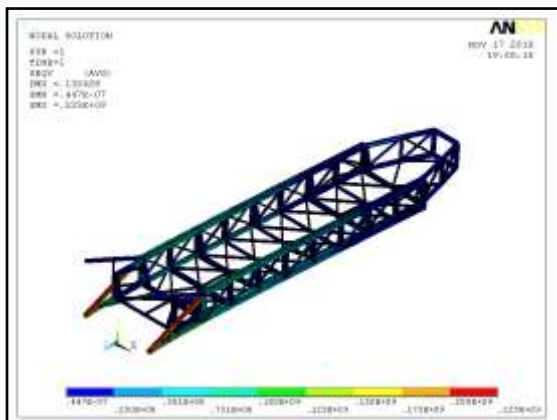

Fig-4: The derrick stress figure under derrick rising

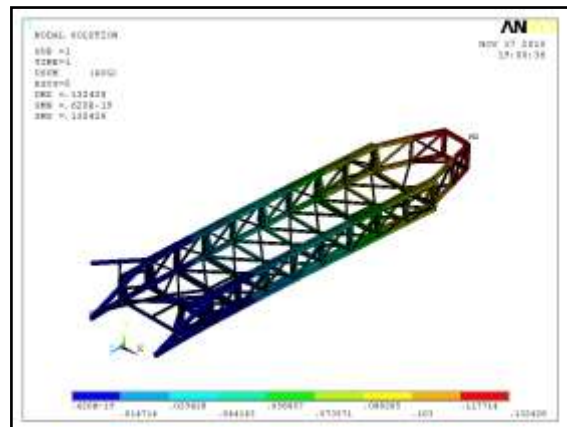

Fig-5: The derrick displacement figure under derrick rising

The restraint forces of node 1,4,42 and 45 were listed in table 1 by the ANSYS in the post-processing module. The force loaded on the substructure by the

derrick was as same as the restraint forces, and in the opposite direction under the condition.

Table 1 The restraint forces under derrick rising (N)

NODE	FX	FY	FZ	MX	MY	MZ
1	-42892.0	-0.32982E+06	0.10302E-05	0	23984.0	-1902.8
4	0	0.45730E+06	0	0	0	0
42	42892.0	-0.32982E+06	0.98837E-06	0	-23984.0	1902.8
45	0	0.45730E+06	0	0	0	0

The calculation of the forces loaded on the substructure by the derrick under maximum hook load

The maximum hook load condition was the drilling condition, the derrick was in the upright state, and the upper section of the derrick was stretched out, and the model was shown in figure 1 (b). The node 1, 42, 115 and 116 were respectively applied by UX, UY, UZ,

ROTY, ROTZ direction constraints (derrick legs and the front supporting feet only rotated around the X). The loads on the Derrick were mainly its gravity 20.85t, the gravity of crane 3.5t, the gravity of hook 4t, maximum hook load 1700kN, the maximum hook load was applied on the four nodes of the mast top. The loaded derrick model was shown in figure 6.

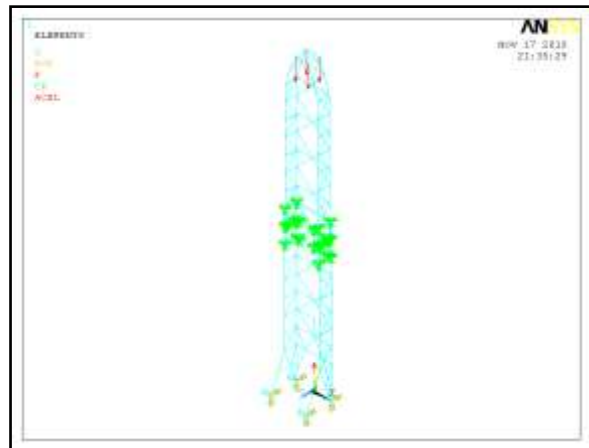

Fig-6: The calculation model under maximum hook load

The derrick stress and displacement figures were shown in figure 7 and 8 after solving.

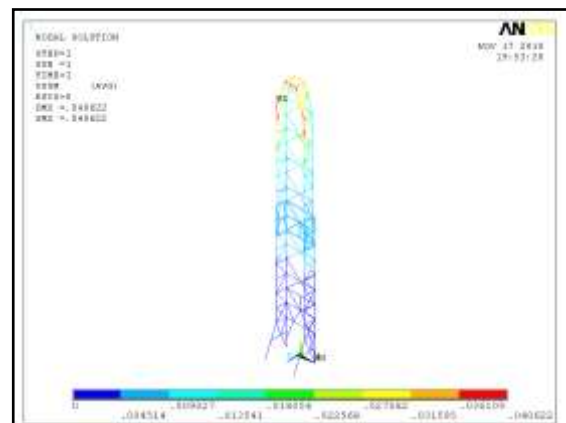
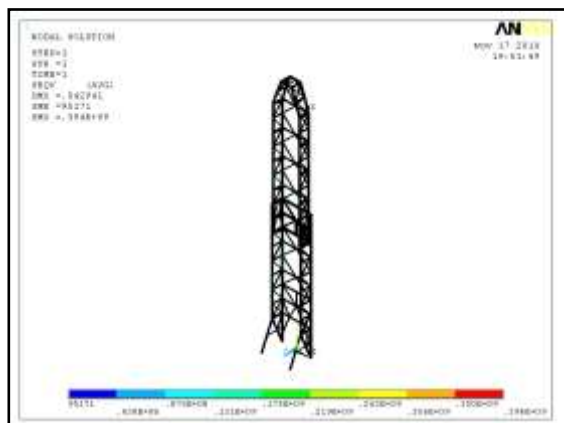

Fig-7: The derrick stress figure under maximum hook load Fig8 The derrick displacement figure under maximum hook load

The restraint forces of node 1, 42, 115 and 116 were listed in table 2 by the ANSYS in the post-processing module. The force loaded on the

substructure by the derrick was as same as the restraint forces, and in the opposite direction under the condition.

Table-2: The restraint forces under maximum hook load (N)

NODE	FX	FY	FZ	MX	MY	MZ
1	-32113.0	0.71795E+06	98819.0	0	96.32	18215.0
42	32113.0	0.71795E+06	98819.0	0	-96.32	-18215.0
115	84.89	0.22361E+06	-98819.0	0	-21.01	-177.80
116	-84.89	0.22361E+06	-98819.0	0	21.01	177.80

The calculation of the force loaded on the substructure by the derrick under casing installation

The model of the derrick under casing installation was as the same as the one under the maximum hook load condition and the upper section of the derrick was stretched out, as shown in figure 1 (b). The node

1,42,115 and 116 were respectively applied by UX, UY, UZ, ROTY, ROTZ direction constraints (derrick legs and the front supporting feet only rotated around the X). The loads on the Derrick were mainly its gravity 20.85t, the gravity of crane 3.5t, the gravity of hook 4t. The loaded derrick model was shown in fig-9.

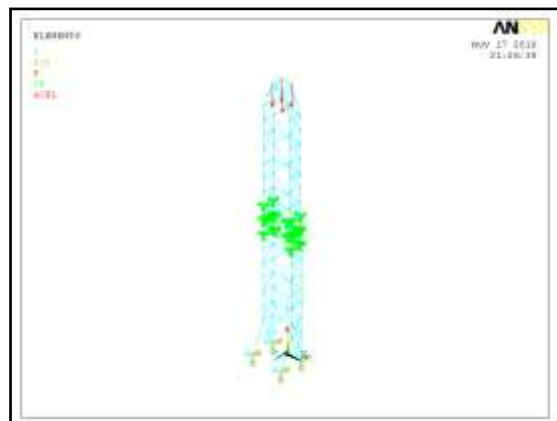

Fig-9: The calculation model under casing installation

The derrick stress and displacement figures were shown in figure 10 and 11 after solving.

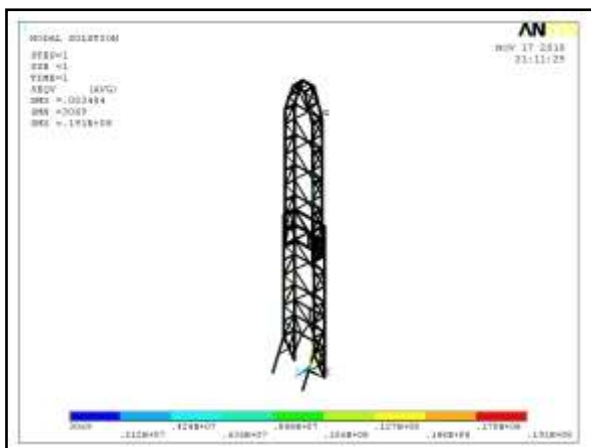

Fig-10: The derrick stress figure under casing installation

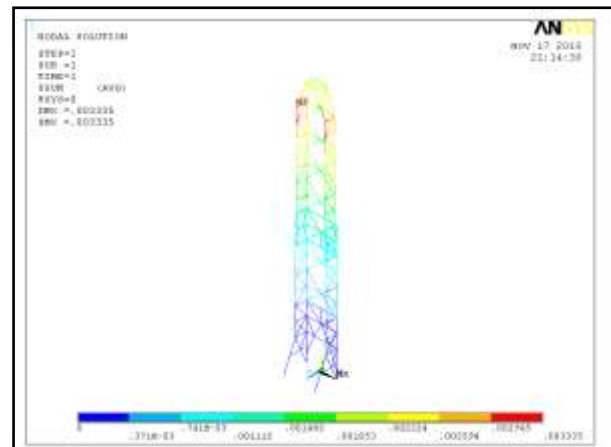

Fig 11 The derrick displacement figure under casing installation

The restraint forces of node 1, 42, 115 and 116 were listed in table 3 by the ANSYS in the post-processing module. The force loaded on the

substructure by the derrick was as same as the restraint forces, and in the opposite direction under the condition.

Table-2: The restraint forces under casing installation (N)

NODE	FX	FY	FZ	MX	MY	MZ
1	-4683.8	0.10006E+06	12408.0	0	14.84	2659.9
42	4683.8	0.10006E+06	12408.0	0	-14.84	-2659.9
115	11.36	28254.0	-12408.0	0	-3.64	-23.10
116	-11.36	28254.0	-12408.0	0	3.64	23.10

Above was the stress and deformation result of derrick under three conditions, because the derrick was not the key research content, further analysis of the derrick was not done. The constraint forces at the bottom of the derrick were only shown in table 1-table 3. The comprehensive load datas for the finite element analysis of the substructure could be provided.

The finite element static analysis of the substructure of ZJ30/1700DB rig

The finite element static analysis of the vertically-telescopic substructure of ZJ30 Rig was done by the software ANSYS, respectively in derrick rising, maximum hook load and casing installation. According to the results of finite element analysis, The section size of weak parts with the big stress and deformation was adjusted to reduce stress and deformation and to ensure the safety of the substructure in use.

The finite element model of the substructure

The substructure was complex, some auxiliary attachments were omitted for finite element analysis, the body bearing substructure model was only established. Because of that the actual stress and deformation of the substructure could not be reflected

by the beam element accurately, the 3D solid model was established and used to calculate. The entity model of the substructure was built by the Solidworks in the article, then imported into ANSYS and calculated as the solid45 element.

The length of the substructure was 12700mm, the width was 6400mm, the hight was 3300mm. The ship was welded by the steel sections and steel plates, the support beams and columns of the substructure were welded by various types of I-steel and channel steel or connected by a pin roll. According to the rig assembly drawings and field measured datas, the substructure model was built by Solidworks, as shown in Figure 12.

The main material of the derrick was Q235, elastic modulus $E=2.1e11$, Poisson's ratio $\mu =0.3$, the density was 7800kg/ m^3 . The entity model of the substructure by Solidworks was imported into ANSYS, and the entity model was meshed by the solid45 element, and the element size is 50mm. A finite element model of the grid was shown in figure 13 with 181121 nodes and 309961 elements.

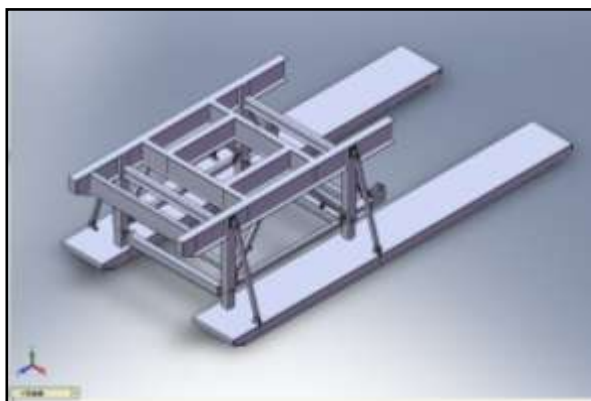

Fig-12: The entity model of the substructure



Fig-13: The meshed model of the substructure

THE STRESS AND DEFORMATION ANALYSIS OF THE SUBSTRUCTURE UNDER THREE CONDITIONS

The stress and deformation analysis of the substructure under the derrick rising

When the derrick rising, the derrick was level, the load on the substructure was the gravity 37t, the

turntable weight 5.86t and the force by the derrick (Table 1). The liquid cylinder pin roll and the main beam of the substructure were loaded by the derrick, the loads were equal with the constraint forces of the node 1, 4, 42, 45 under derrick rising, but the direction was opposite. After the solution the stress and displacement were listed in figure 14 and 15.

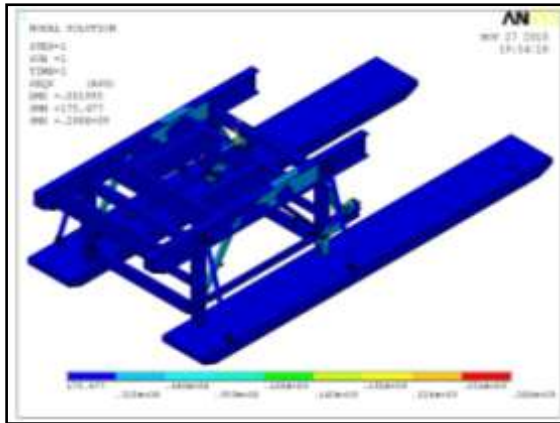

Fig-14: The substructure stress figure under derrick rising

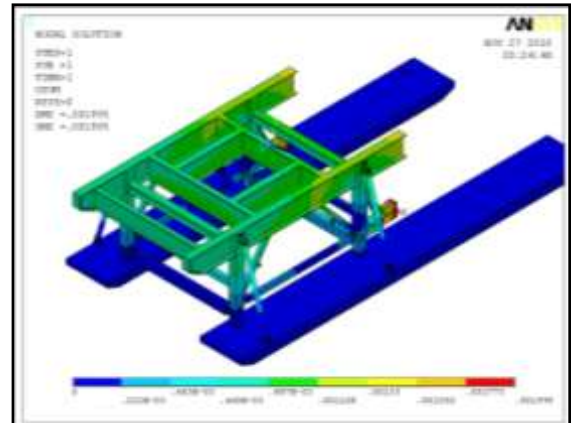

Fig-15: The substructure displacement figure under derrick rising

The maximum stress of the substructure was 262MPa from figure 14, the maximum displacement value was 1.9mm, and the position of the MX is marked in figure 15. Because of the complexity of substructure and the big size, and the stress and deformation of the substructure was analyzed in segments.

The stress and deformation analysis of the main beams and the turntable beams

The stress and deformation of the main beams and the turntable beams were shown in figure 16. The maximum stress value was 115MPa; the position was in the place where the derrick legs and the substructure were connected (MX marked place in figure 16). The maximum displacement value is 1.486mm.

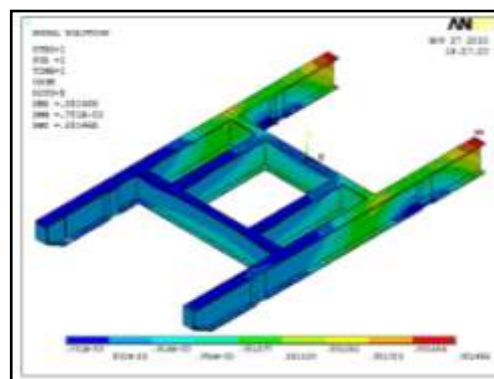
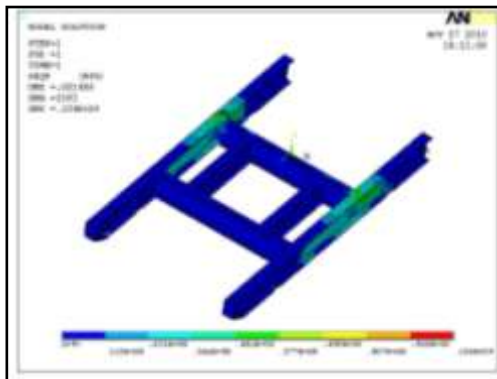

Fig-16: The stress and displacement figure of the main beams and turntable beams under derrick rising

The stress and deformation analysis of the upright columns

The stress and deformation of the upright columns were shown in figure 17. The maximum stress value of

the columns was 262MPa, and the position was shown in figure 17, where the pin roll connected to cylinder, the maximum displacement was 2mm.

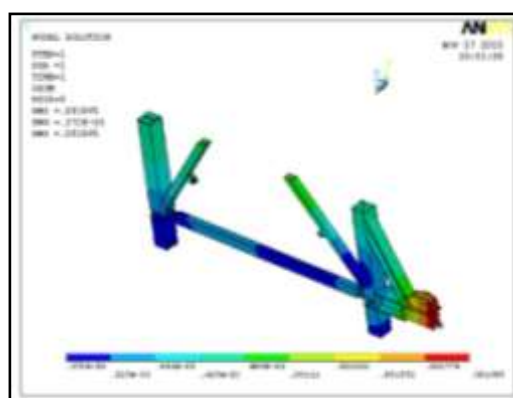
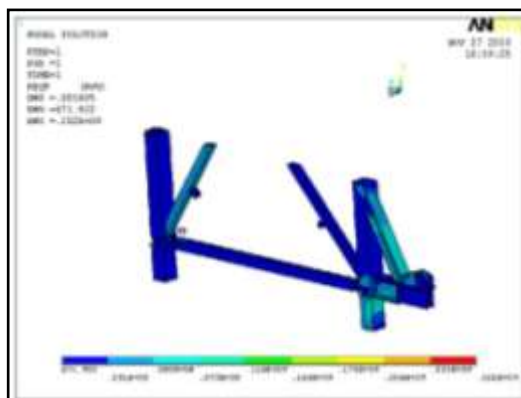

Fig-17: The stress and displacement figure of the upright columns under derrick rising

The stress and deformation analysis of the drilling string beams

When the derrick rising, the loads on the drilling string beams were the gravity, the maximum stress

value was 1.14MPa, the maximum displacement was 0.8mm, and the positions were marked MX in figure 18.

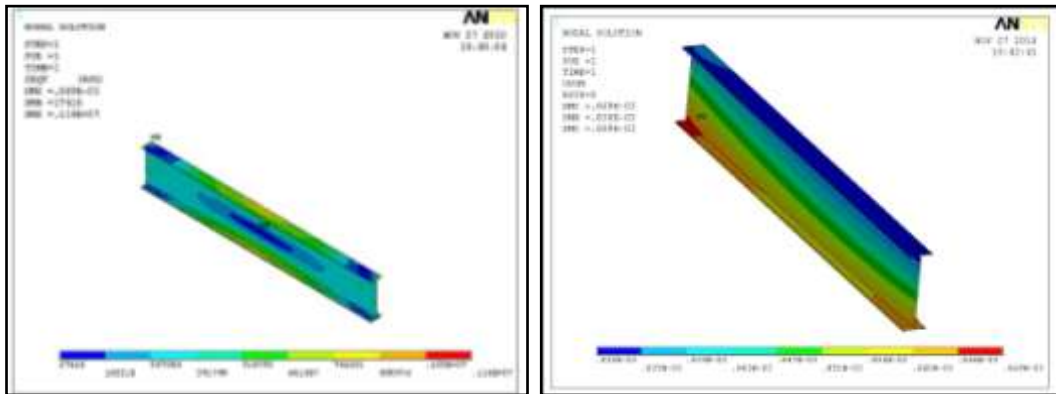

Fig-18: The stress and displacement figure of the drilling string beams under derrick rising

The stress and deformation analysis of the boats

The stress and deformation of the boats were shown in figure 19, the maximum stress value was

45.1MPa, the maximum displacement value was 0.172mm, the position was shown in the figure 19.

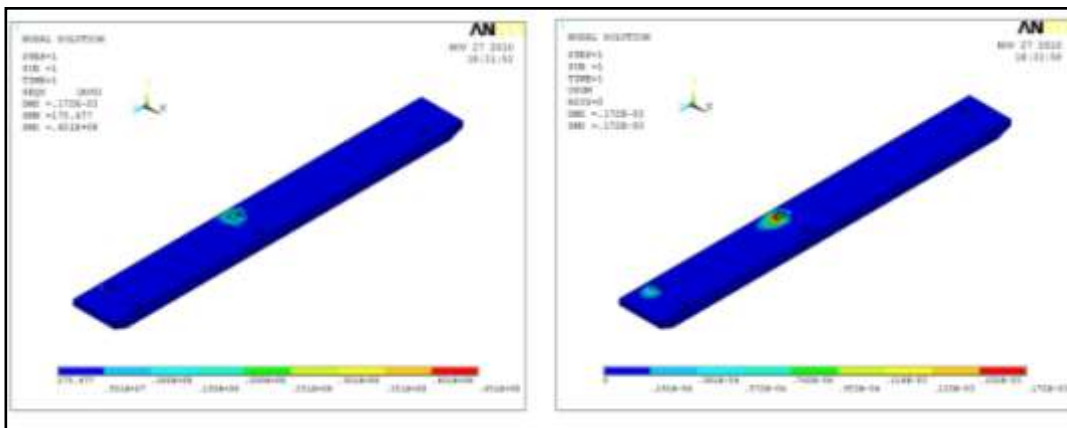

Fig-19: The stress and displacement figure of the boats under derrick rising

The stress and deformation analysis of the diagonal braces

The stress and deformation of the diagonal braces were shown in figure 20, the maximum stress value is

29.3MPa, the maximum displacement value is 1.1mm, and the position was shown as MX in figure 20.

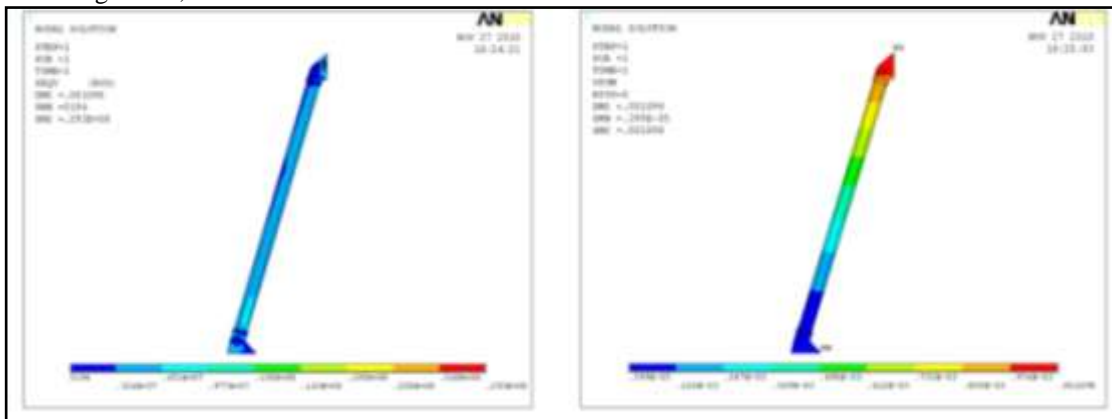

Fig-20: The stress and displacement figure of the diagonal braces under derrick rising

The stress and deformation analysis of the substructure under maximum hook load

Under the maximum hook load, the loads of the substructure were mainly the gravity 37T, the gravity of the turntable 5.86t, the gravity of drilling strings 90t and the force by the derrick (Table 2). The load direction of the derrick to the substructure is opposite to the direction of restraining force.

The stress and displacement of the substructure could be listed in the figure 21 and figure 22 after the solution. The maximum stress of the substructure was 310MPa from figure 21, the maximum displacement was 4.6mm, and the position was the MX in figure 22.

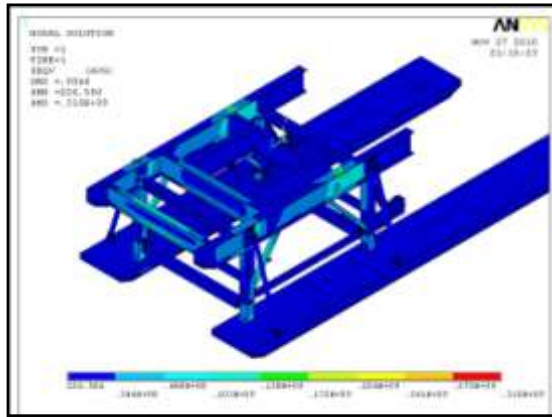

Fig-21: The substructure stress figure under maximum hook load

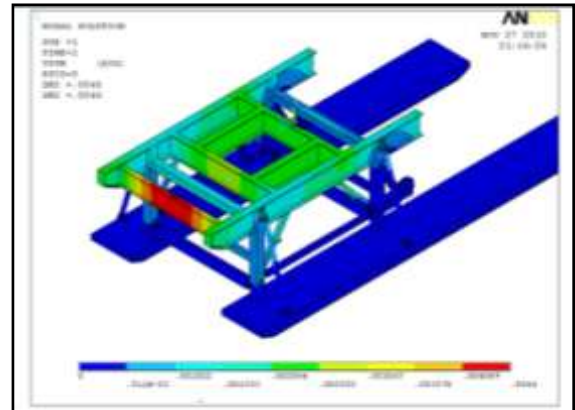

Fig -22: The substructure displacement figure under maximum hook load

The stress and deformation analysis of the main beams and the turntable beams

The stress and deformation of the main beams and the turntable beams were shown in figure 23. The

maximum stress value was 256MPa, the maximum displacement value was 2.7mm, and the position was MX marked in figure 23.

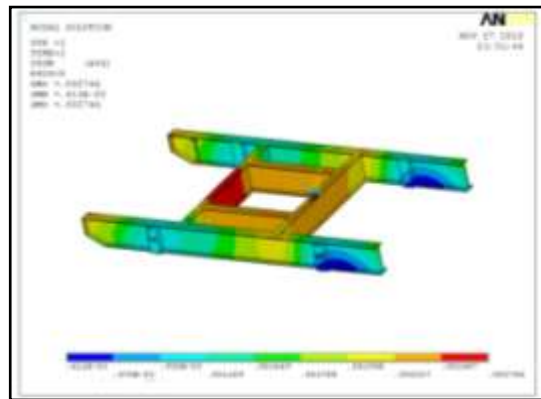
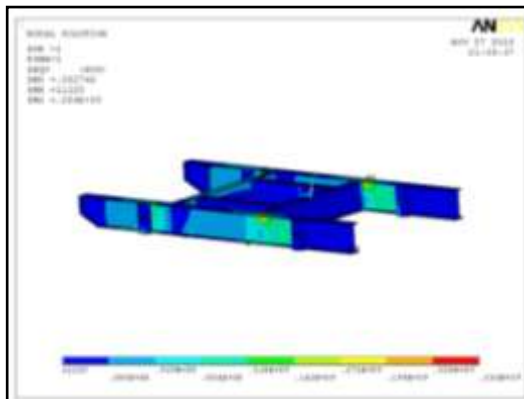

Fig-16: The stress and displacement figure of the main beams and turntable beams under maximum hook load

The stress and deformation analysis of the upright columns

The stress and deformation of the upright columns were shown in figure 24. The maximum stress value of

the columns was 119MPa, the maximum displacement was 2mm, and the position was MX marked in fig-24.

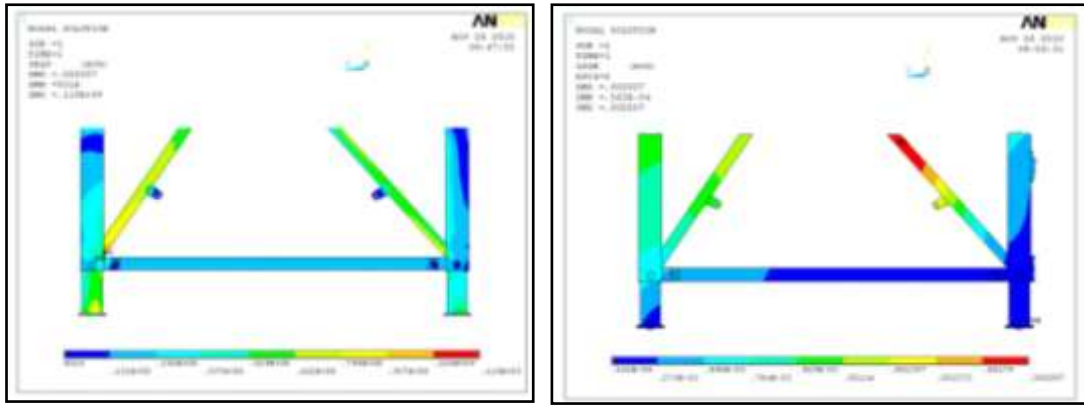

Fig-24: The stress and displacement figure of the upright columns under maximum hook load

The stress and deformation analysis of the drilling string beams

When maximum hook load, the loads on the drilling string beams were the gravity and the gravity of

the drilling strings, the maximum stress value was 102MPa, the maximum displacement was 4.6mm. The positions were MX marked in figure 25.

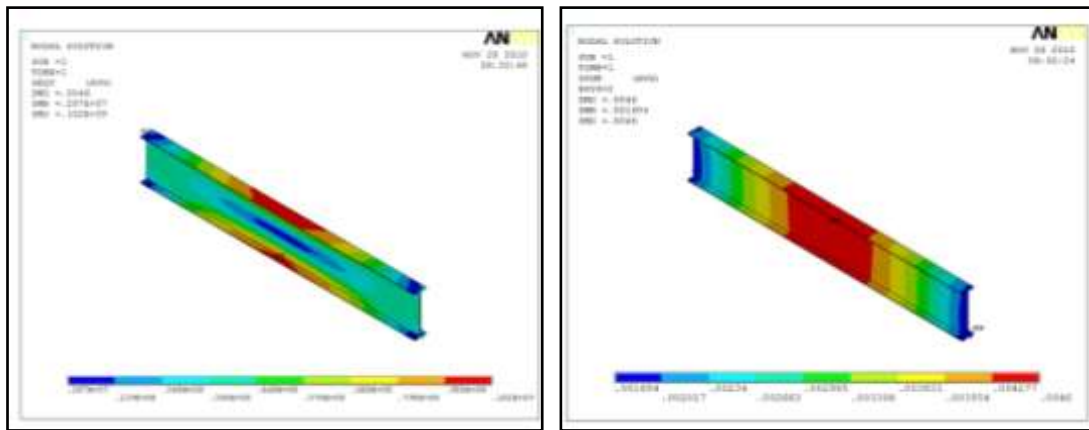

Fig-25: The stress and displacement figure of the drilling string beams under maximum hook load

The stress and deformation analysis of the boats

The stress and deformation of the boats were shown in figure 26, the maximum stress value was

135MPa, the maximum displacement value was 0.3mm, the deformation was small, and the positions were MX marked in figure 26.

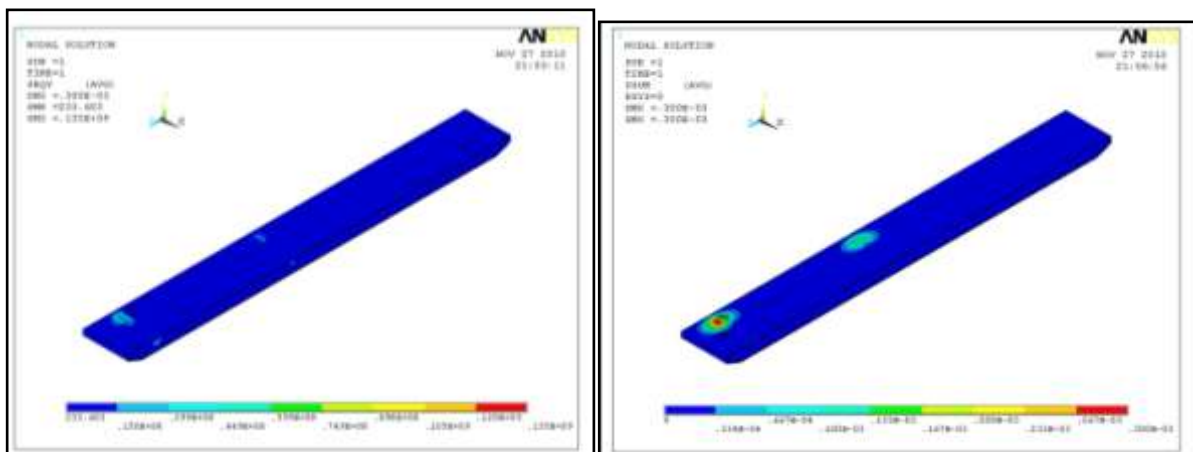

Fig-26: The stress and displacement figure of the boats under maximum hook load

The stress and deformation analysis of the diagonal braces

The stress and deformation of the diagonal braces were shown in figure 27, the maximum stress value is

310MPa, the maximum displacement value is 1.12mm, and the position was MX marked in figure 27.

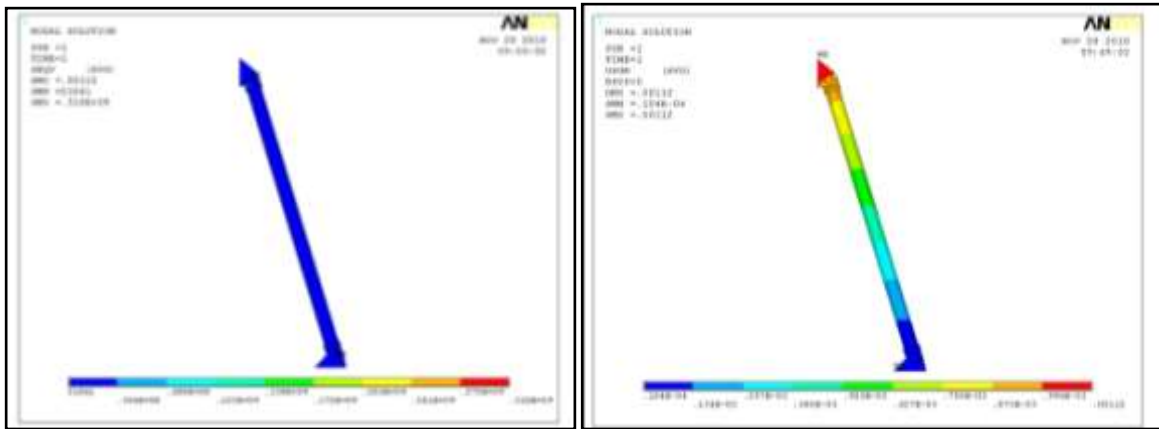

Fig-27: The stress and displacement figure of the diagonal braces under maximum hook load

The stress and deformation analysis of the substructure under casing installation

Under the casing condition, the loads on the substructure were the gravity 37t, the gravity of the turntable 5.86t and the turnplate beam load 1700KN, the drilling strings load 90t and the force on the main beam by derrick (Table 3), the load direction of the

derrick to the main beam is opposite to the direction of restraining force.

The stress and displacement of the substructure could be listed in the figure 28 and figure 29 after the solution. The maximum stress of the substructure was 308MPa from figure 21, the maximum displacement was 5.7mm, and the position was the MX in figure 29.

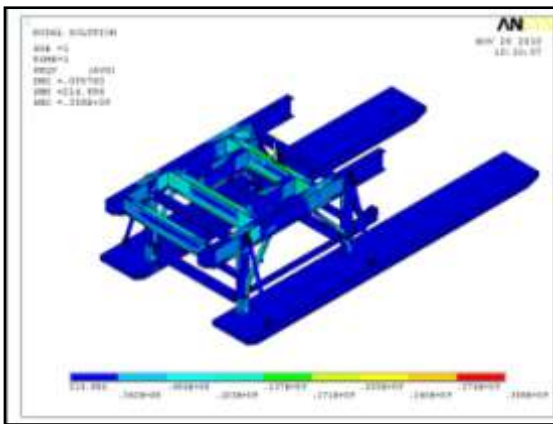

Fig-28: The substructure stress figure under casing installation

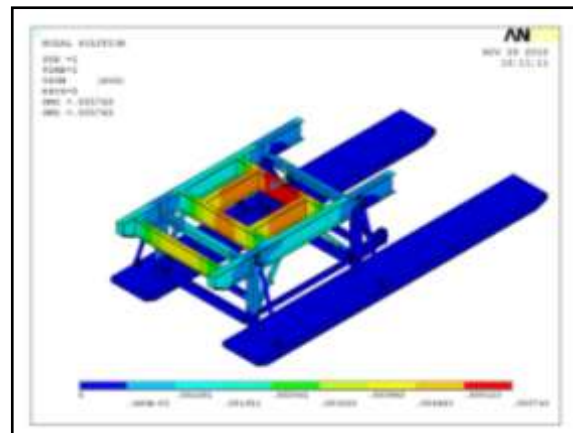

Fig-29: The substructure displacement figure under casing installation

The stress and deformation analysis of the main beams and the turntable beams

The stress and deformation of the main beams and the turntable beams were shown in figure 30. The

maximum stress value was 149MPa, the maximum displacement value was 5.7mm, and the position was the red area with MX marked in figure 30.

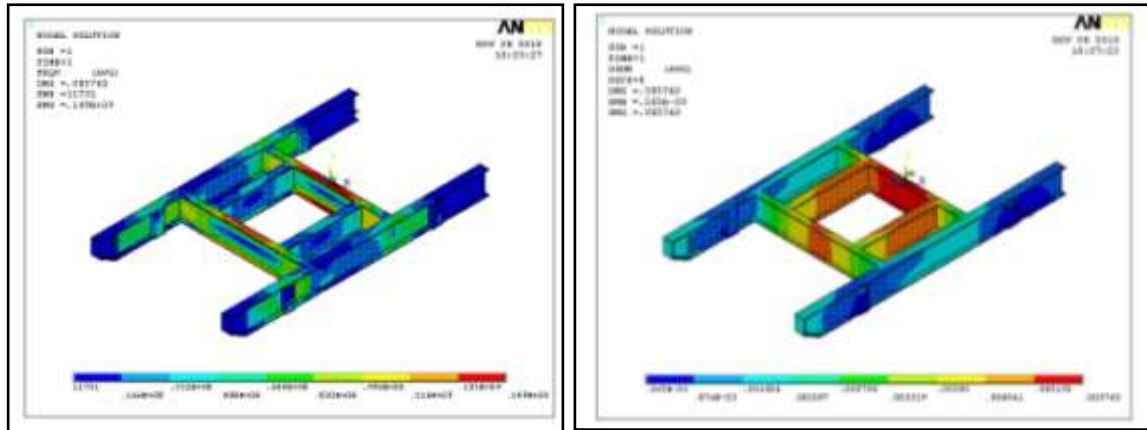

Fig-30: The stress and displacement figure of the main beams and turntable beams under casing installation

The stress and deformation analysis of the upright columns

The stress and deformation of the upright columns were shown in figure31. The maximum stress value of the columns was 132MPa, the maximum displacement was 2.2mm, and the position was MX marked in figure31.

The stress and deformation analysis of the drilling string beams

The stress and deformation of the drilling string beams were shown in figure 32. Under casing installation, the loads were the gravity and the gravity of the drilling strings, the maximum stress value was 102MPa, the maximum displacement was 4.4mm. The positions were MX marked in figure 32.

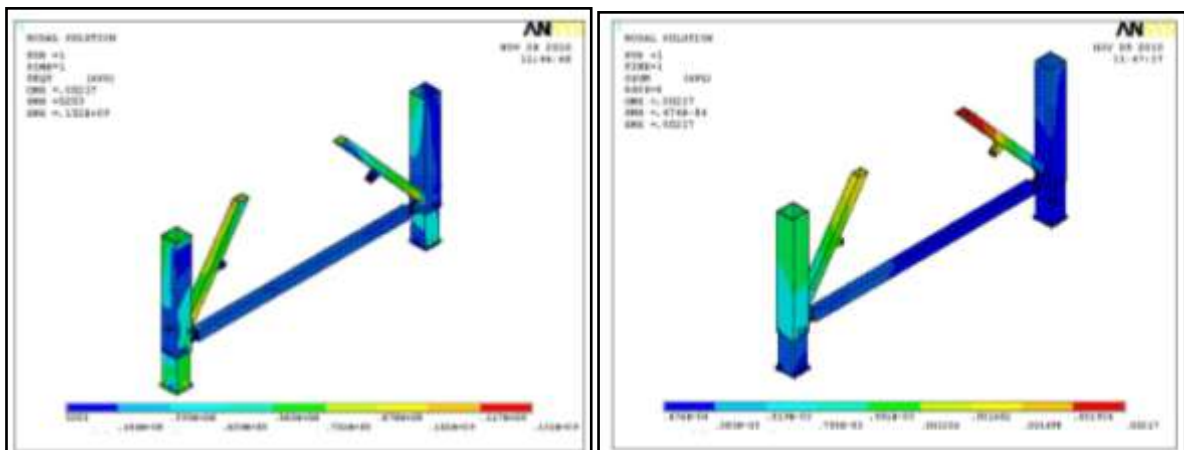

Fig-31: The stress and displacement figure of the upright columns under casing installation

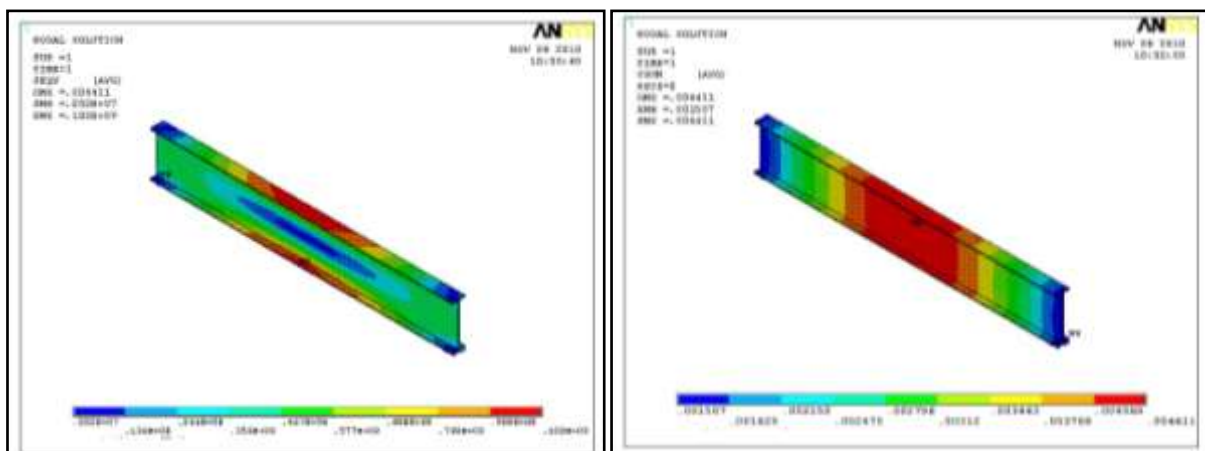

Fig-31: The stress and displacement figure of the drilling string beams under casing installation

The stress and deformation analysis of the boats

The stress and deformation of the boats were shown in figure 33, the maximum stress value was 137MPa, the maximum displacement value was 0.3mm.

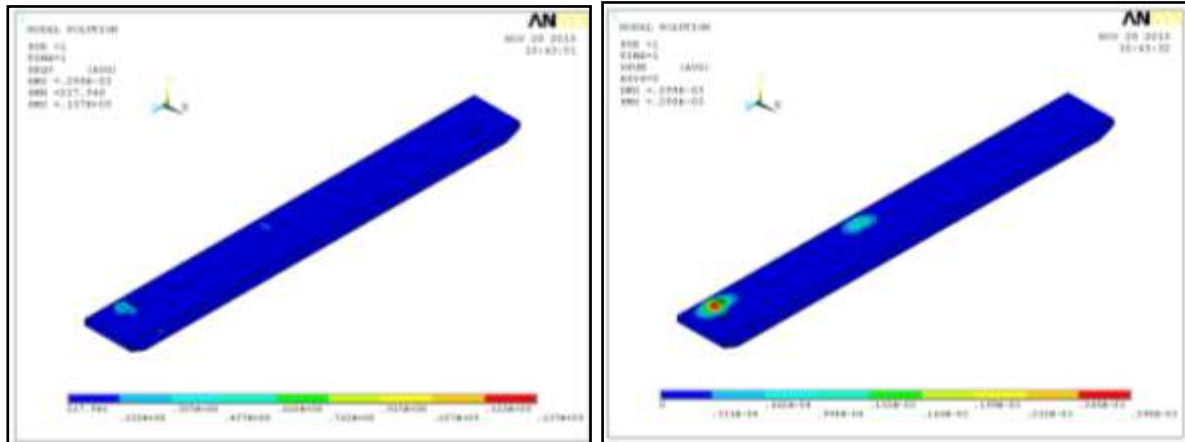

Fig-33: The stress and displacement figure of the boats under casing installation

The stress and deformation analysis of the diagonal braces

The stress and deformation of the diagonal braces were shown in figure 34, the maximum stress value was

308MPa, the maximum displacement value was 0.93mm, and the position was MX marked in figure 34.

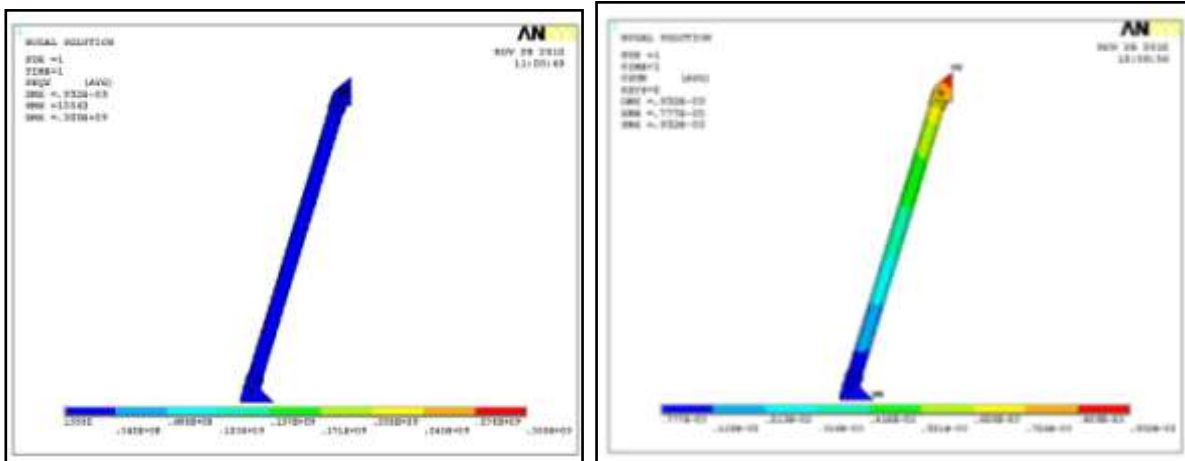

Fig-34: The stress and displacement figure of the diagonal braces under casing installation

THE STRESS AND DEFORMATION COMPREHENSIVE ANALYSIS OF THE SUBSTRUCTURE UNDER THREE CONDITIONS

The stress and deformation comprehensive analysis of the main beams and the turntable beams

The maximum stress value and the maximum displacement value of the main beams and turntable beams were listed in Table 4 under three conditions, The maximum stress value was 256MPa under the

maximum hook load, as shown in figure 23, appeared in the main beam. The yield limit of Q235 steel is 235MPa, so maximum stress value of the main beams exceeded the allowable stress, and was safe in derrick rising and casing installation, but dangerous under maximum hook load, and the main beams should be redesign. The maximum deformation value appeared in casing installation, and the deformation value was 5.7mm and small.

Table-4: The stress and displacement comparison of the main beams and turntable beams under three conditions

Conditions	Derrick rising	Maximum hook load	Casing installation
Maximum stress values	115MPa	256MPa	149MPa
Maximum displacement values	1.5mm	2.7mm	5.7mm

The stress and deformation comprehensive analysis of the upright columns

The maximum stress value and the maximum displacement value of the upright columns were listed in Table 5 under three conditions, The maximum stress

value was 262MPa under the derrick rising, as shown in figure 17, appeared on the pin rolls where was connected with hydraulic cylinder. The maximum deformation value was 5.7mm under three conditions.

Table-5: The stress and displacement comparison of the the upright columns under three conditions

Conditions	Derrick rising	Maximum hook load	Casing installation
Maximum stress values	262MPa	119MPa	132MPa
Maximum displacement values	2mm	2mm	2.2mm

The stress and deformation comprehensive analysis of the drilling string beams

The maximum stress value and the maximum displacement value of the drilling string beams were listed in Table 6 under three conditions. The load was only the gravity under derrick rising, the maximum stress value was 1.14MPa; the maximum displacement was 0.8mm from Table 6. The maximum stress values

were the same under maximum hook load and casing installation, and were 102 MPa, as shown in figure 25 and figure 32, but the maximum displacement values were slightly different, the maximum displacement value was 4.6mm, the positions were MX marked in figure 25. The yield limit of the steel Q235 was 235MPa, so the drilling string beams were safe under three conditions, the safety factor was above 1.5.

Table-6: The stress and displacement comparison of the drilling string beams under three conditions

Conditions	Derrick rising	Maximum hook load	Casing installation
Maximum stress values	1.14MPa	102MPa	102MPa
Maximum displacement values	0.8mm	4.6mm	4.4mm

The stress and deformation comprehensive analysis of the boats

The maximum stress value and the maximum displacement value of the boats were listed in Table 7 under three conditions. The maximum stress value was the smallest under derrick rising, the maximum displacement value was the lowest, the maximum stress value was the largest under the casing installation and

was 137MPa, the position was shown in figure 33. The yield limit of the steel Q235 was 235MPa, and the safety factor was above 1.5 through calculating, so the boats were safe under three conditions. The maximum displacement was 0.3mm under the maximum hook load and the casing installation, the deformation was small.

Table-7: The stress and displacement comparison of the boats under three conditions

Conditions	Derrick rising	Maximum hook load	Casing installation
Maximum stress values	45.1MPa	135MPa	137MPa
Maximum displacement values	0.17mm	0.3mm	0.3mm

The stress and deformation comprehensive analysis of the diagonal braces

The maximum stress value and the maximum displacement value of the diagonal braces were listed in Table 8 under three conditions. The maximum stress

value was the largest under maximum hook load with the stress concentration phenomenon, and was 310MPa which appeared in the upper pin roll, as shown in figure 27. The maximum displacement was 1.18mm; the position was marked in figure 20.

Table-8 :The stress and displacement comparison of the diagonal braces under three conditions

Conditions	Derrick rising	Maximum hook load	Casing installation
Maximum stress values	29.3MPa	310MPa	308MPa
Maximum displacement values	1.1mm	1.12mm	0.93mm

The improvement design of the substructure based on the finite element results

The maximum stress value was the largest under maximum hook load, the yield limit of the Q235 steel was exceeded, the safety factor was lower than 1, this was dangerous in working; the pin rolls of hydraulic cylinder rising, the upright columns main beams and the diagonal braces had the phenomenon with the stress concentration, therefore, it is necessary to redesign the main beams and the pin rolls.

Improved method: Two steel plates with 1000mm long and 12mm thick were affixed in inside main beams with maximum stress, the size of I beam of the front

turntable beam was changed from the original 700mm *200mm to 700mm * 250mm, the diameter of the pin rolls were change from 50mm to 80mm, from 80mm to 100mm, after recalculation under maximum hook load, the stress distribution was shown in figure 35and figure 36.

The maximum stress value of the substructure after improving was 184MPa under maximum hook load, the maximum displacement value was 4.4mm, and the original stress value was 310MPa, the original displacement value was 4.6 mm, the maximum stress value decreased significantly after redesigning.

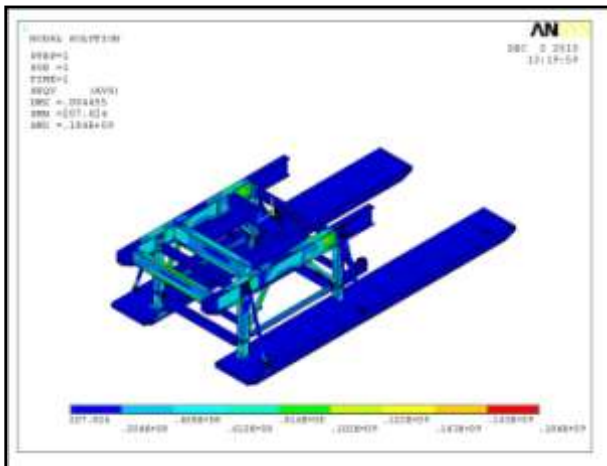

Fig-35: The improved substructure stress figure

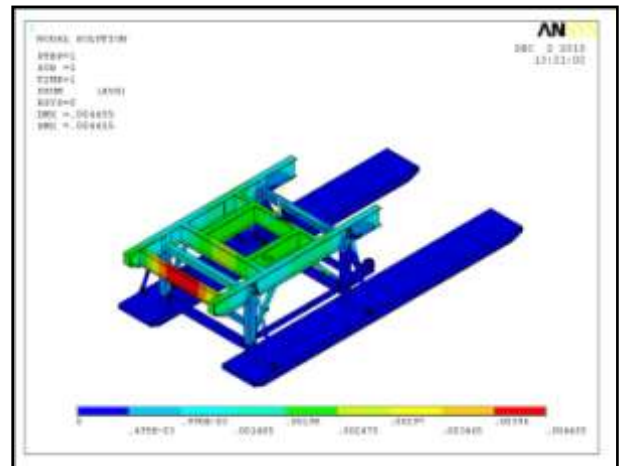

Fig-36: The improved substructure displacement figure

The stress and displacement of the main beams of the improved substructure were shown in figure 37 and figure 38, the largest stress value of the improved main beams decreased from 256MPa to 113MPa, the position was marked MX in the red area. The yield limit of the Q235 steel was 235MPa, the safety factor was more than 2. The largest stress value of the turntable

beams decreased from 85.4MPa to 62.7Mpa, the safety factor was higher. The largest displacement decreased from 2.7mm to 2.6mm, the position was marked MX in the red area, the deformation value was still small and the stiffness requirement was met. So the improved substructure could be used safely in drilling work.

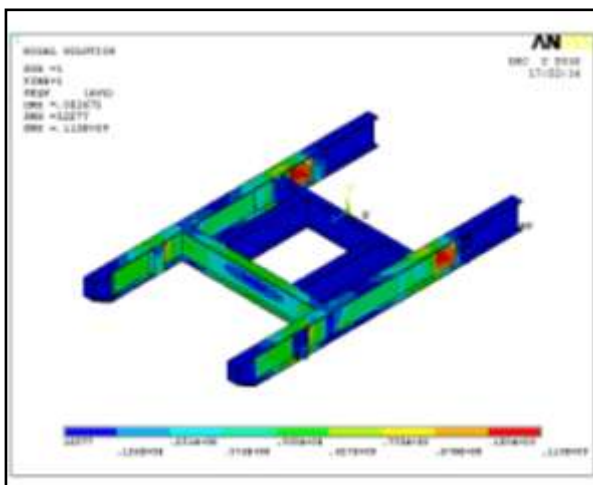

Fig-37: The stress figure of improved main beams and the turntable beams

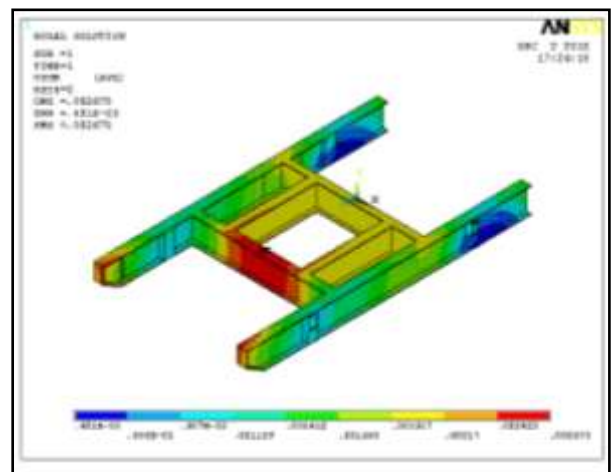

Fig-38: The displacement figure of improved main beams and the turntable beams

CONCLUSIONS

According to the function of rig substructure function and drilling technology requirement of the substructure, the research and improvement design of Vertically-telescopic Substructure of ZJ30 Rig was carried out in the article, the main completed work and conclusions were as follows:

(1) The combination loads of the finite element analysis on the substructure were analyzed under derrick rising, maximum hook load and casing installation. The derrick model was established for the finite element calculation as the beam element, the loads on the substructure were obtained under the three conditions through calculating, and the comprehensive data were provided for the element analysis of the substructure.

From the calculation results of the three conditions, the vertical upward force 329.8 kN where the front leg of the derrick loads on the substructure and the vertical downward load 457.3kN where the hydraulic cylinder rised would produce a trend that made the whole rig go backward, the weight distribution of the substructure must be calculated in designing, and backward moment would be balanced by the weight of the ramp and the catwalk .Under maximum hook load, the loads where the front legs of the derrick loaded on the substructure were 718kN and the loads where front supporting feet of the derrick loaded on the substructure were 223.6kN, and the direction was downward. In the front support rod at the foot of the role 223.6kN 22.36t load and the both direction were downward. Compared with the maximum hook load, the loads of the derrick on the substructure were smaller under the casing installation.

(2) Considered the complex structure of the substructure and the section size was too large, the calculation error would be made by the simplified substructure into spatial element beams, and the substructure deformation would not be reflected accurately, so the the spatial entity elements were used to establish the substructure finite element model, fully in accordance with the main actual carrying body of the substructure. The stress and deformation of the whole substructure and its parts were obtained based on the finite element calculation and analysis results under the above three conditions. From the results, when the rig was located in the cement foundation and the displacement and deformation of most parts of the substructure was small and less than 10mm; but thd stress of a very few of parts was high (beyond the material yield limit), the overall stess of the substructure was moderate. The stress value of the drilling string beams was less than 102MPa, the stress value of the boats was less than 137MPa under the conservative load combinations (the loads on the derrick and the turnplate beams were the maximum hook loads, and at the same

time the turnplate beams were full of the drilling string beams). Under maximum hook load, the stress 256Mpa appeared in the local area of the main beams, the stress 310 MPa appeared in the pin rolls of the diagonal braces; the stress 262MPa appeared in the pin rolls of the upright columns under derrick rising.

(3) The local area with large stress of the substructure was redesigned based on the finite element calculation results, parts of the main substructure were improved, the size of the pin rolls of the hydraulic cylinder, the upright columns and the diagonal braces were changed into bigger. After the recalculation, the everywhere stress fell to the limit of the yield. So the improved substructure could be used safely in drilling operation.

NOMENCLATURE

Q_{\max} ——the maximum hook load of the rig(kN);

$k_{\text{储}}$ ——the coefficient of weight reserve;

$q_{\text{柱}}$ ——average weight of per metre drill string(N/m);

L_{\max} ——maximum drilling depth(km);

$Q_{\text{立根}}$ ——the drilling string load(kN).

REFERENCES

1. Pan Hao, Li Jialing, Chi Shenggao; New rig derrick and substructure design model. Petroleum machinery, 33, 2005; (2): 21-23.
2. Chi Shenggao; A new rig derrick and substructure design and research. Petroleum machinery, 28, 2006 (3): 385-386.
3. Lv Lan, Chen Jun; The substructure and developing direction of the middle deep well land drilling rig derrick substructure. Petroleum field machinery, 2007;36(1): 17-20.
4. Liu Yang, Liu Jubao, Luo min; The finite element analysis and application. Beijing: China Power Press, 2008, 111-114.
5. Zhang Hongxin, Guan Dianzhu; Finite element theory and the application of ANSYS 11.0. Beijing: Mechanical Industry Press, 2009; 256-285.
6. Zou Longqing, Li Cuiyan, Wang Shuzhong; Research on the static and dynamic characteristics of ZJ40-2250DB rig derrick and substructure . Oil field machinery, 2007; 36 (2): 15-17.
7. Madenci, Erdogan; Finite Element Method And Applications in Engineering Using Ansys.Springer-Verlag New York Inc Guven.The, 2005; 30-55
8. Wen Hongli, Gao Xueshi, Yang Dongping; The finite element analysis of the bearing capacity of ZJ70DB rig base . Petroleum field

- machinery, 2007; 36 (11): 36-38.
9. Wang Shisheng, Zhang Hong; DZ450/9-S rig base static and dynamic characteristics analysis. University Journal, 2002; 26 (1): 66-68.
 10. Zhang Zhaohui; ANSYS 11 structural analysis engineering application case analysis. Beijing: Mechanical Industry Press, 2008; 432-484.
 11. ANSYS .Inc .ANSYS Elements Reference[M].Eleventh Edition, SAS, IP Inc, 2001;90-110