

Original Research Article

Health Promotion Model of Surgical Site Infection Prevention in Yogyakarta

Triyani Marwati, Dr AA Subiyanto, Totok Mardikanto, J. Priyambodo

Faculty of Public Health, Ahmad Dahlan University, Jl. Prof. Soepomo, Janturan Warungboto Yogyakarta

***Corresponding author**

Triyani Marwati

Email: triyanim@yahoo.com

Abstract: Surgical Site Infections (SSI) are the most common type of nosocomial infection 14 – 16 % occurrence of all nosocomial infection incidence among hospitalized patient which potentially increase mortality rate or prolong hospital stay until 7-10 days thus have significant financial implications. The main objective of this present study aimed to formulate health promotion model assessed from variables expected to have influence: prevention effort, patient safety, stakeholder support, health promotion, and hospital care cost. The method was Analytical survey research design with cross sectional approach was used to collect quantitative data supported by qualitative information. Structural equation modeling (SEM) was performed by AMOS. In results stakeholder support was directly affected by prevention (55.7 %) and patient safety policy (30.4 %). Health promotion was directly affected by prevention (12.9 %) and patient safety policy (29.4%), and stakeholder support (63.2%). Based on SEM analysis, inter-correlation among variables can be formulated into a model.

Keywords: Surgical Site Infections (SSI), infection, Health promotion.

INTRODUCTION

Patient safety is a system whereby hospital assures patient care to safer by: risk assessment, identification and management regarding risky matters to patient, incidence report and analysis, the ability to learn from the incident, subsequent follow-up, as well as solution implementation to minimize risk [1,2].

The most common risk is exposure to nosocomial infection with around 14-16% incidence on hospitalized patients being due to surgical site infections[3]. This type of infection occurred in the part of the body where the operation took place within 30 days post surgery or up to a year after the procedure in case of an implant[4-6]. SSI is estimated to occur in 2-5 % of patient undergo invasive surgical procedures in America. SSI has annual incidence of around 500,000 and associated with about 7-10 days post-surgery hospitalization addition[7].

METHODS

Quantitative data supported with qualitative information, obtained using analytical survey research design with cross sectional approach. Independent variables consist of: Prevention (X_1) which consist of: knowledge, attitudes, actions, hand-washing, personal protective equipment, sterilization, aseptic technique, prophylaxis antibiotic, and patient safety policy (X_2),

while dependent variables consist of stakeholder support and health promotion.

Validity test noted that all tested items was considered as valid, while reliability test proved that research instruments were reliable (research data was analyzed using AMOS –SEM (3)

RESULTS:

Stakeholder support was directly affected by prevention (55.7 %) and patient safety policy (30.4 %). Health promotion was directly affected by prevention (12.9 %) and patient safety policy (29.4%), and stakeholder support (63.2%). Based on SEM analysis, inter-correlation among variables can be formulated into a model.

DISCUSSION:

Overview of research location

PKU Muhammadiyah Hospital, which consists of Unit 1 & 2, is one of private hospitals in Yogyakarta as one of benefaction unit of Persyarikatan Muhammadiyah, located at KH. Ahmad Dahlan street 20 (Unit 1) and Wates district road kilometer 5.5 Gamping Sleman (Unit 2), both are accredited in 16 service unit and classified as type B hospital. The hospital has 4 kinds of service (surgeons, internists, pediatric and obstetrics) supported by sub specialists in

department of neurology, otolaryngology, ophthalmology, dermatology, etc.

Hospital management of PKU Muhammadiyah very concerned with patient safety, by which infection incidence monitoring is applied. It was reported in 2012 that 12 % of infection was surgical site infection[8]. Several health promotions have been conducted, from pre, during, to post-surgery, such as “5 moments of

washing hand” activity suggested by WHO. However, the outcome has not reach maximum level due to infection control monitoring system has not running well. Therefore, infection prevention model need to be formulated based on various variables correlated with infection control, such as: prevention acts, patient safety policy, stakeholder support and empowerment in form of health promotion expected to reduce surgical site infection incidence.

A. Univariate analysis:

Table 1: Respondents characteristics

Number	Parameters	Percentage	Description
1	Age	19-28	Years old
2	Gender	Female	82.3%
3	Education	College student	76%
4	Occupation	Nurse	90.6%
5	Working period	11 years	59.4%

Analysis results from AMOS software briefly presented in the figure below.

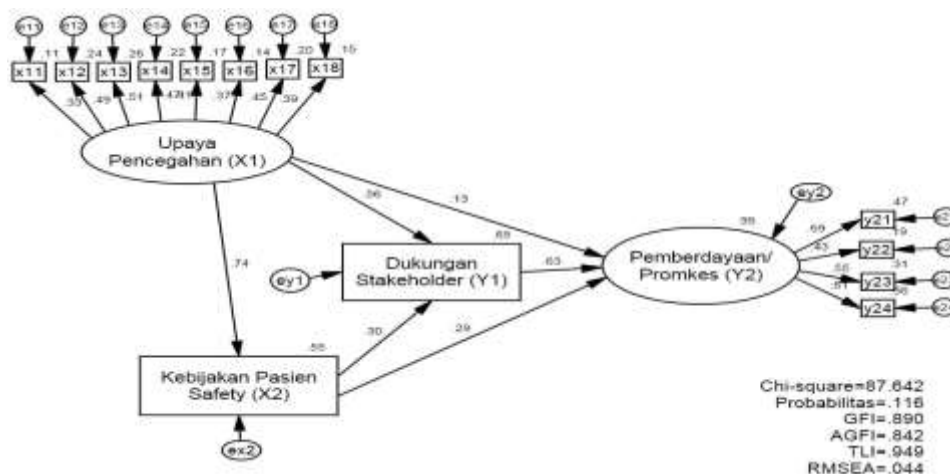

Fig-1: Regression analysis model using determined variables with SEM analysis

Based on analysis results above, obtained Chi-square was 87.642 at $p > 0.05$, indicated that fundamental measure of the overall fit (like hood-ratio) can be interpreted as no significant different between predicted and real observed covariant matrix input and likelihood-ratio Chi Square was statistically was qualified. GFI (Goodness of fit index) obtained was 0.890 showed marginal fit (relatively good fit model) in $0.8 \leq GFI \leq 0.90$ interval. AGFI (Adjusted Goodness of

Fit Index) obtained was 0.8422, classified as marginal fit (good fit model) in $0.8 \leq AGFI \leq 0.90$ interval. LI (Tucker Lewis Index), also known as non-nor med fit index (NNFI), in this analysis was 0.949 or 94.9%, which classified as qualified since the recommended index is $> 90\%$. Meanwhile, RMSEA (Root Mean Square Error of Approximation) was 0.044, classified as marginal fit (close-to-feasible model) and qualified for $RMSEA < 0.05$.

Table 2: Direct and indirect effect of exogenous on endogenous variables

Endogenous Variable/ Dependent	Exogenous Variable/ Independent	Effects (%)		
		Direct	Indirect	Total
Stakeholder support (Y ₁)	Prevention (X ₁)	55.7	22.5	78.1
	Patient safety policy (X ₂)	30.4	--	30.4
Empowerment/ Health promotion (Y ₂)	Prevention (X ₁)	12.9	71.2	84.1
	Patient safety policy (X ₂)	29.4	19.2	48.7
	Stakeholder support (Y ₁)	63.2	--	63.2

Table above showed that direct effect from prevention on empowerment/health promotion was 12.9%, whereas indirect effect was 71.2%. Directly effect of patient safety policy variable empowerment/health promotion was 29.4%, whereas indirect effect was 19.2%. Direct effect of stakeholder support on empowerment/health promotion was 63.2%. The results indicated that stakeholder support effect was more dominant than patient safety policy and prevention.

3. SEM Analysis

SEM (Structural Equation Modeling) analysis by AMOS software running resulted Chi-square of 87.642 at $p > 0.05$, classified as qualified. Fundamental measure from overall fit (likelihood-ratio) showed that

predicted and actual observation covariant matrix input was not significantly different. GFI (Goodness of fit index) of this study was 0.890 or 89.0%, classified as marginal fit for being above 80-90% (good fit model). AGFI (Adjusted Goodness of Fit Index) of the study was 0.842, classified as marginal fit (relatively good fit model). TLI (Tucker Lewis Index), or known as non-normed fit index (NNFI), in present study was 0.949 or 94.9%, classified as qualified for being above 90% as recommended. RMSEA (Root Mean Square Error of Approximation) of the study was 0.044, classified as qualified and marginal fit (nearly-good fit model) for being below 0.05. The results are briefly presented below.

Table 3: Overall test results of SEM model analysis

No.	Qualification Indicator	Recommended standard*)	Result	Classification
1.	Chi Square	<ul style="list-style-type: none"> $p > 0.05$ (good fit) 	87.642 $p > 0.05$	good fit model
2.	GFI	<ul style="list-style-type: none"> GFI > 0.90 = good fit $0.8 \leq \text{GFI} \leq 0.90$ marginal fit (relatively good fit model) 	0.890	Marginal fit (relatively good fit model)
3	AGFI	<ul style="list-style-type: none"> GFI > 0.90 = good fit $0.8 \leq \text{GFI} \leq 0.90$ marginal fit (relatively good fit model) 	0.842	Marginal fit (relatively good fit model)
4.	TLI	Recommended TLI is ≥ 0.90	0.949	Good fit model
5.	RMSEA	RMSEA < 0.05 indicated marginal fit (nearly-good fit model) <ul style="list-style-type: none"> $0.05 \leq \text{RMSEA} \leq 0.08$ indicated good fit model RMSEA > 0.1 indicated poor fit model 	0.044	Marginal fit (nearly-good fit model)

*) Source: Ghozali (2010).

B. Analysis bivariate

DISCUSSION

a. Prevention (X_1)

Prevention consists of knowledge, attitude, action, hand washing, personal protective equipment, sterilization and antibiotic. In this present study, prevention had high qualification with 59.6 % [7]

There were several sub variables included:

1. Knowledge; respondents considered all health workers very knowledgeable on prevention of surgical site operation infection.
2. Most of respondents (95 %) showed proactive attitude toward infection prevention such as hand-washing habit prior to any action, whereas other 5 % mentioned that they often forget to wash their hands.
3. Measure done by health workers from planning to evaluation has always been in nursing control.
4. Personal protective equipment has been well-applied by health workers, such as the use of masks, handscoon, and action suit, etc.

5. Sterilization consist of physical, chemical, and biological sterilization applied only to measure total bacterial number and to assure that it remains below threshold due to limited infrastructure and high workload.
6. Prophylaxis antibiotic is supposed to be utilized in operating room, however, it also used in ward in order to apply cross test

B. Patient safety policy (X_2)

According to respondents opinion, patient safety policy in this present study was classified as moderate of 36.5 % (n=38). During interview R (1), it was revealed that there are 6 goals made in hospital regarding patient safety policy: (1) Activity identification was still in process although special training for medical personnel has been done; (2) communication regarding confirmation label given by doctors has not entirely applied; (3) medicine classification, such as red label for highly alert medicine, or green for minimal risk, has been applied;

(4) the risk for patient to fall or drop the patient wristbands are also anticipated as recorded in medical record assessment, operation safety, etc.; 5) infection controlling program is carried out by several methods, such as “five moments of washing hands” for hygiene, education through leaflet, etc., however, the monitoring was not in maximum level and only applied in several wards (6) operation safety during time out and sign in – sign out had not been well-documented.

There are six objectives of patient safety handling according to International Joint Commission: correct identification of patient, improvement of communication effectively, improvement of safety in high-alert medications, assurance of correct place, correct procedures, and correct patient surgery, reducing infection risk from health worker, reducing the risk of worse error on patient[6,7].

C. Stakeholder support (Y₁)

Stakeholder support in this study was 46.1% (N=50). Thus it can be said that according to respondents, stakeholder support in PKU Muhammadiyah Unit 1 and Unit 2 was classified as moderate. It was indicated by result of interview in R (2^o) that hospital management was really concern with surgery site infection prevention through the establishment of hospital infection controlling team which specially work on monitoring and investigating infection potential in hospital. Besides, profession organization in the hospital play important supporting role despite independent funding system.

D. Empowerment/Health promotion (Y₂)

Analysis on health promotion variable in present study was categorized as high of 58 % (N=50) according to respondents opinion. Respondents (1) noted that health promotion was yet to be applied in PKU Muhammadiyah, but they acknowledge the acts and effort to prevent surgical site infection by the application of Prevention Principals of Surgical Operation Infection through reduction of infection risk from patient and prevention of microorganism transmission from health workers, environment, instruments and from patients themselves, during pre-, intra-, and post- operation.

Variables included in health promotion are: Advocation, empowerment, and social capital, which

REFERENCES

1. Johnstone MJ; Patient safety ethics and human error management in ED contexts: Part I: Development of the global patient safety movement. *Australasian emergency nursing journal*, 2007; 10(1):13-20.

can be implemented by commitment to develop health workers competency through education and training as well as commitment for infrastructure complement in line with expectations. Public accountability can be carried out through immediate response and report when patient safety incidence occurred to be evaluated and discussed for correct solution and prevention for not being repeated. The role of profession organization such as Indonesian National Nurses Association was still limited due to newly-establishment hence their activity is limited to administrative activity such as membership fee collection and practice license assistance.

CONCLUSIONS AND SUGGESTIONS

A. Conclusions

Based on data analysis result and discussion, it could be concluded that:

1. Prevention had direct effect on stakeholder support (55.7 %),
2. Patient safety policy had direct effect on stakeholder support (30.4 %).
3. Prevention had direct effect on health promotion (12.9 %)
4. Patient safety policy had direct effect on health promotion (29.4%)
5. Stakeholder had direct effect on health promotion (63.2%)
6. Overall results based on SEM analysis indicated that correlation among variables can be formed into a model.

B. Suggestions

Based on data analysis result and conclusions, it can be suggested that:

1. The model can be applied as efforts to prevent surgical site infection using several variables, such as: prevention, patient safety, stakeholder's support and health promotion, in support of variables that already exist.
 2. For public health office, the model can be applied and developed for hospital with similar system.
 3. This research is expected to be developed by other researcher, particularly using prevention variable with relatively low effect on surgical site infection.
2. Small SD, Barach P; Patient safety and health policy: a history and review. *Hematology/oncology clinics of North America*, 2002; 16(6):1463-1482.
 3. Barie PS, Hydo LJ; Epidemiology, risk factors, and outcome of multiple organ dysfunction syndrome in surgical patients. In *Multiple Organ Failure* (pp. 52-67). Springer New York. 2000.

4. Owens CD, Stoessel K; Surgical site infections: epidemiology, microbiology and prevention. *Journal of Hospital Infection*, 2008; 70:3-10.
5. Tang R, Chen HH, Wang YL, Changchien CR, Chen JS, Hsu KC, Wang JY; Risk factors for surgical site infection after elective resection of the colon and rectum: a single-center prospective study of 2,809 consecutive patients. *Annals of surgery*, 2001; 234(2):181-189.
6. Gaynes RP, Culver DH, Horan TC, Edwards JR, Richards C, Tolson JS; National Nosocomial Infections Surveillance System. Surgical site infection (SSI) rates in the United States, 1992–1998: the National Nosocomial Infections Surveillance System basic SSI risk index. *Clinical Infectious Diseases*, 33(Supplement 2), S69-S77. 2001.
7. Anderson DJ, Podgorny K, Berríos-Torres SI, Bratzler DW, Dellinger EP, Greene L, Kaye KS; Strategies to prevent surgical site infections in acute care hospitals: 2014 update. *Infection Control & Hospital Epidemiology*, 2014;35(06):605-627.