

Economic Analysis for Replacement of 11kv Overhead Koteshwor Feeder by Underground Distribution System

Ganesh Kumar Sah*, Raj Kumar KC

Department of Mechanical Engineering, Pulchowk Campus, Institute of Engineering, Tribhuvan University, Nepal

DOI: [10.36347/sjet.2020.v08i03.001](https://doi.org/10.36347/sjet.2020.v08i03.001)

| Received: 11.11.2019 | Accepted: 19.11.2019 | Published: 07.03.2020

*Corresponding author: Ganesh Kumar Sah

Abstract

Original Research Article

Cost effective, Aesthetic and Reliable energy supply is the need of any mankind. In this study, economic analysis for replacement of 11 kV overhead distribution feeder by 11kV underground cable is done with reference to Koteshwor Feeder under Baneshwor Distribution and Consumers Service. The reliability indices like SAIDI, SAIFI, ENS etc. is performed by using DIgSilent PowerFactory software. The reliability of overhead distribution system is evaluated by using real system data system and similarly, historical IEEE standard data is used for underground distribution system. The reliability indices are compared for both distribution systems. Result shows that interruption in the overhead system is more than underground distribution system, the energy not supplied to the customer by overhead distribution system is also more than underground distribution system. The replacement cost estimation is performed by using Nepal Electricity Authority (NEA) unit rate and KEI industries quoted price for NEA underground project. The B/C ratio and Present Worth value for the 25-year period of useful life shows that the replacement of the existing overhead distribution system by underground distribution system is financial suitable and can be payback by revenue save from the Energy Not Supply (ENS) lower value of underground distribution system than overhead distribution system. In order to get the continuous of supply, esthetic and public safety in electricity distribution field one may have to bear initially extra cost to use underground distribution systems which finally get payback. Thus, in case of densely populated city like Kathmandu, underground distribution system is reasonable requirement for continuous supply, esthetic and public safety in electricity distribution filed.

Keywords: Aesthetic, Reliable, Indices, SAIDI, SAIFI, ENS, Interruption.

Copyright © 2020: This is an open-access article distributed under the terms of the Creative Commons Attribution license which permits unrestricted use, distribution, and reproduction in any medium for non-commercial use (NonCommercial, or CC-BY-NC) provided the original author and source are credited.

INTRODUCTION

As the present scenario of Nepal distribution line all electrical, telephone and telegraph wires are suspended from high poles, creating strange and crowded streetscapes. Unmanaged city planning, haphazard road digging and dust pollution have defaced beautiful Kathmandu. Our city is in a mess. Electric pylons dangling overhead or even lying along the roadside, hindering mobility, posing greater risks of accidents and short circuits have made the matters worse. The tangled web of overhead cables all over the city have added to visual pollution. The electric, telephone wires and cables jumbled and dangling in a web like structure from the poles have contributed in disfiguring the city's beauty too.

There are two ways to distribute electric energy to customers: overhead (OH) lines and underground (UG) cables. Although power system reliability analysis is a mature research area, there is a

renewed interest in updating available network models and formulating improved reliability assessment procedures. Underground cables offer immense benefits. It helps in ensuring uninterrupted power supply and it can transmit power across densely populated areas where land is costly or aesthetically sensitive or facing right of way problem which applies in the case of Kathmandu Valley. Underground electricity distribution system also prevents any possible hazards in the event of accidents and falling of electricity poles. Simply placing the wires underground does not constitute an efficient system. Underground distribution system is the ultimate solution of the distribution problem that confronts every Electric Utility operating in progressive towns and cities. The financial success of an electrical undertaking depends on supplying efficient and reliable service in an economical manner, and in order to secure this result the distribution system must be carefully designed and properly installed.

Safety is the top priority in electric utility. This work describes the complex electrical safety issues related to grounding underground distribution system and protecting electrical workers who are working in electrical vault and who are utilizing energy. There are lots of uncertain problems and challenges are associated with its practical implementation and it cannot be scoped for all the feeders. And fault clearing time period for this is another challenge for underground distribution. Although high cost of underground distribution system this can be payback after few years of installation by efficient and reliable operation of system.

METHODOLOGY

In this dissertation work, methodology starts with literature review of various related literature followed by data collection from Baneshwor substation record file. Collected data is analyzed and categorized in momentary, planned and unplanned interruptions (sustained) according to IEEE guidelines [1]. Frequency and duration of planned, unplanned and momentary interruption is noted since 2073 BS. Failure rate of existing overhead Koteshwor feeder is determined based on data from past 2073 BS. For designed underground Koteshwor Feeder standard failure rates and repair duration, various literatures are used. To determine customer number in feeder, data from different Distribution and consumer service is collected and analyzed. DIgSILENT PowerFactory standard library is also used to determine some electrical parameters values. Also, the dismantle cost of overhead line is obtained from Nepal electricity authority. Per kilometer unit rate for new construction and installation of underground line is also obtained from Nepal electricity authority.

Methodology Steps

- Technical data is collected of selected Feeder. (Single line diagram, equipment specification, line length, type of conductors and cable, number of transformers, load, energy sales etc.)
- Validate the DIgSILENT PowerFactory reliability assessment tool by using the standard IEEE RBTS 2- bus system (Which is created for educational purpose).
- Calculation of momentary and sustainable failure frequency and duration of interruption in existing overhead feeder for a time duration by following IEEE is guidelines.
- Simulate and run reliability assessment of equivalent existing overhead single line diagram

of feeder in DIgSILENT PowerFactory (Using NEA data).

- Calculate selected reliability indices like SAIFI, CAIFI, SAIDI, MTTF, MTBF, and ENS for the equivalent overhead feeder using DIgSILENT PowerFactory.
- Simulate and run reliability assessment of underground single line diagram of feeder in DIgSILENT PowerFactory (IEEE historical data).
- Calculate selected reliability indices like SAIFI, CAIFI, SAIDI, MTTF, MTBF, and ENS for the underground feeder using DIgSILENT PowerFactory.
- Compare the reliability indices of existing overhead line and underground line obtained from DIgSILENT PowerFactory results.
- Dismantle cost of overhead line and installation cost of underground cable is calculated. (By taking NEA cost estimation and practice)
- The economic benefit of the designed underground system is estimated and the replacement of the overhead line by underground cable is economically justified or not is evaluated/checked.

RESULTS AND DISCUSSIONS

Koteshwor Feeder of Baneshwor substation under Baneshwor distribution and consumer service of Nepal Electricity Authority (NEA) is located central location of Kathmandu valley. it contains 34 distribution transformers having rating of 100KVA, 150 kVA, 200 kVA, 300 kVA, 400 KVA, 500 kVA with total rating capacity of 6850 KVA and mainly DOG ACSR conductor of different length for different branches.

Standard RBTS 2 Bus is used as test systems reliability validation because they were created for educational purposes and all reliability data of components are informed [2]. After the comparison of reliability indices obtained from simulation in DIgSILENT PowerFactory and standard 2 RBTS results shows highest deviation is seen in the value of SAIDI which is -0.516%.

Reliability Evaluation

By using GPS map of Koteshwor feeder, length of each section and connected load in each section is determined. The single line diagram for Koteshwor Feeder is simulated in DIgSILENT PowerFactory is shown in below Figure-1. And reliability evaluation assessment is done

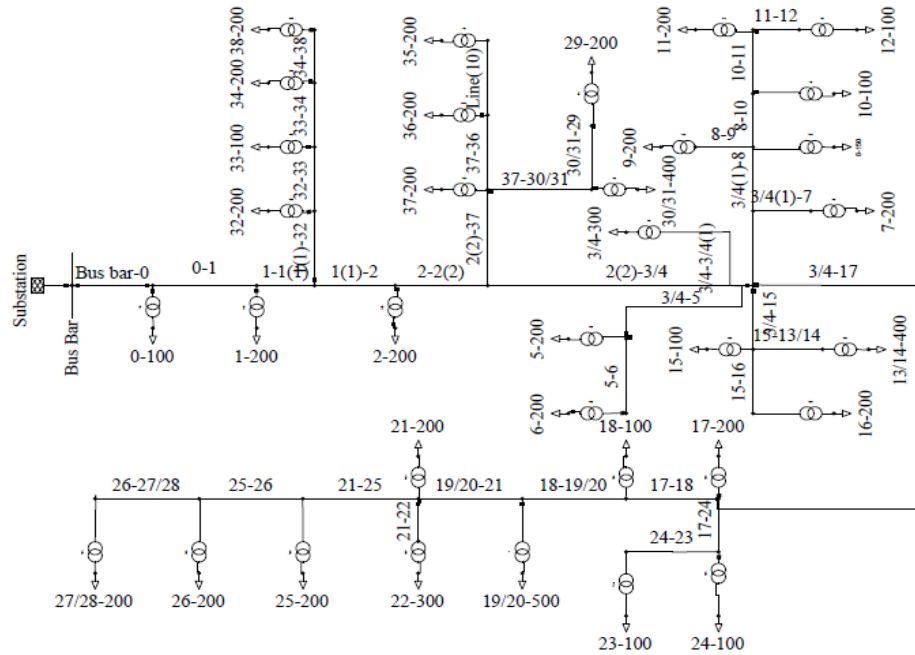

Fig-1: Simulation of Koteswori Feeder in DigSILENT PowerFactory

Customer based reliability indices how often each customer connected to the system faces sustained power interruption and duration of each interruption. The calculations considering sustained outage only. In all the calculations mentioned below interruptions caused to the customers due to grid failure is not included. SAIFI SAIDI and CAIDI are the most important reliability indices in distribution system.

Interruptions that lasts not more than 5 minutes are called momentary interruption. Since these interruptions are not sustained, they are not considered to evaluate reliability indices like SAIFI, SAIDI, and CAIDI etc. Momentary interruption is only used to calculate MAIFI. The real failure rate and repair rate of Koteswori feeder as shown in Table-1 [3].

Table-1: Failure Rate and Repair Duration of Koteswori Feeder

	Total Number of Fault	Total Repair Time
2075	52	48:12
2074	48	48:09
Average	50	48:10
Fault Clearing Time in Hour		48:10
Length of the Feeder in km		9.452
Failure rate per year per km per Annum		5.29
Repair duration per failure		0.963

The failure and repair rate IEEE historical data used for underground distribution system shown in Table-2 [4].

Table 2: IEEE Historical Data for Underground Distribution System

Equipment/Rate	Failure Rate	Repair Time/Replacement Time (Hour)
Transformer (Per Year)	0.0041	73.4
Cable (Per km Per Year)	0.0291617	27.2
Cable Joint/Terminator (Per Year)	0.000307	30.2
Conductor (Per km Per Year)	0.062008	4.6
Conductor Joint/Terminator (Per Year)	0.001848	15.3

After running the reliability assessment of existing overhead line and underground line following

results were obtained from DigSILENT PowerFactory as shown in Table-3.

Table-3: Reliability indices of existing overhead and designed underground distribution system

Reliability Indices	Index	Unit	Designed Underground System	Existing Overhead System
System Average Interruption Frequency Index	SAIFI	1/Ca	0.337	49.99
System Average Interruption Duration Index	SAIDI	h/Ca	11.98	48.156
Customer Average Interruption Duration Index	CAIDI	h/Ca	35.554	0.963
Average Service Availability Index	ASAI		0.988632	0.9945
Average Service Unavailability Index	ASUI		0.0013679	0.005497
Energy Not Supplied	ENS	MWh/a	65.919	329.38
Average Energy Not Supplied	AENS	MWh/Ca	0.009	0.042
Average Customer Curtailment Index	ACCI	MWh/Ca	0.026	0.042
Average System Interruption Frequency Index	ASIFI	1/a	0.337035	49.99
Average System Interruption Duration Index	ASIDI	h/a	11.9852	48.155

For existing overhead distribution system, the result shows that energy not served due to failure of feeder is 329.38 MWh/a. which means in one year 329380 unit is not supplied from feeder to the one customer in one year. Similarly, for the underground distribution system, the result shows that energy not served due to failure of feeder is 65.919 MWh/a. which means in one year 65919 unit is not supplied from feeder to the one customer in one year.

ECONOMIC ANALYSIS

Dismantling Cost Estimate

Some of the material is useful after dismantling the existing overhead distribution. Thus, some material cost can be saved by investing in labor for dismantling process. The cost saves from dismantle is obtained from NEA unit rate. The total cost save from dismantling of existing overhead distribution system is as shown in below Table-4 [3].

Table-4: Total Cost Save from Dismantle of Existing Overhead Distribution System

Total Cost Save from Koteswor Feeder							
Name of Feeder	Cost Save NRs.						
	Materials Cost Save (1)	Labor Cost Expenditure (2)	Total Cost Save (3=1-2)	Contingency 5 % (4 = 5% of 3)	Total with Contingency (5 = 3 - 4)	VAT @ 13 % (6 = 13% of 5)	Grand Total Cost Save (NRs) (7 = 5 + 6)
Koteswor	9,313,217	411,233	8,901,984	445,099	8,456,885.18	1,099,395.07	9,556,280.25

Cost Estimate of Underground Distribution System

Cost required to install underground distribution system for Koteswor Feeder as shown in below Table-5. The cost is determined by replacing

each branch of the Koteswor Feeder by cable considering branch length and its connected. All the unit rate is taken from KEI industries Co. Ltd. quoted for the NEA underground project [5].

Table-5: Total Cost Estimation of Underground Distribution System

Total of Cost of Koteswor Feeder							
Name of Feeder	Cost Estimate NRs.						
	Materials Cost Save (1)	Labor Cost Expenditure (2)	Total Cost Save (3=1+2)	Contingency 5 % (4 = 5% of 3)	Total with Contingency (5 = 3 + 4)	VAT @ 13 % (6 = 13% of 5)	Grand Total Cost Save (NRs) (7 = 5 + 6)
Koteswor	11,053,050	10,591,352	21,644,402	1,082,220	22,726,622	2,954,461	25,681,083

Investment Decision

After the calculation of total cost required for replacement of existing overhead distribution system by underground distribution system, the investment

decision is checked by Energy Not Served (ENS) value of underground and existing overhead distribution system as shown in below Table-7.

Table-7: Energy Save Cost and Cost Required for Replacement

Cost Save From Reliability Analysis		
ENS of the underground distribution	65.919	MWh/a
Save due to ENS per annum	263.461	MWh/a
At NRs 13 Per unit rate, Revenue Saved	3424993	Source: NEA
Cost Required for cable replacement		
Cost of the underground distribution	25681082.89	NRs
Dismantle Cost Save from Existing OHDS	9,556,280.25	NRs
Extra Cost Required for replacement	16,124,802.63	NRs

By taking 25-year useful life of the underground distribution system and at 10% MARR rate B/C ratio is calculated as shown in below Table-8.

Table-8: B/C Ratio for Investment

Taking life of 25 years	
Initial investment, NRs	16124802.63
Useful life (year)	25
MARR 10%	0.1
Annual revenue saved, NRs	3424993
(PW) Benefit NRs	31088798.52
B/C ratio	1.93
PW (10%), of cash flow, NRs	14963995.89

As B/C ratio is greater than one, the investment is accepted (For replacement of existing overhead distribution system feeders). Also, present

worth of cash flow is positive, the investment can be done. The returned of the investment is calculated as shown in below Table-9.

Table-9: Payback Periods of Investment

Payback Period			
Year	Cash Flow	PW of Net Cash Flow	Cumulative Cash Flow (NRs)
0	-16124803	-16124803	-16124803
1	3424993	3113630	-13011173
2	3424993	2830573	-10180600
3	3424993	2573248	-7607352
4	3424993	2339316	-5268036
5	3424993	2126651	-3141384
6	3424993	1933319	-1208065
7	3424993	1757563	549498
8	3424993	1597785	2147282
9	3424993	1452531	3599814
10	3424993	1320483	4920297

The cumulative cash flow is positive between 6th and 7th year. Hence, the payback period lies between 6th and 7th year. That is after 7th year of replacement of the existing overhead feeder of Koteswori by underground distribution system investment can be payback.

Further, the cost of the designed underground distribution system is 2.37 times higher than designed overhead distribution system.

CONCLUSIONS

After evaluation of the reliability indices of the existing overhead system it shows that SAIFI value is 49.99 per annum which is very high as compared to IEEE standard network which is 0.337 for underground distribution system. This shows that how unreliable

Koteswori feeder is and how many improvements it needs to be required. Also, the energy not supplied (ENS) value of existing system is almost five times higher value as compared to designed underground distribution system.

The Cost of the underground distribution system is almost 2.37 times higher than overhead distribution system. By investing NRs. 411,233.04 in labor expenditure total NRs. 9,556,280.25 useful material can be saved from dismantling of existing overhead distribution system. Also, NRs. 3,424,993.00 revenue per annum is saved because of lower ENS value of designed underground system. Thus, considering these cost B/C ratio, Present Worth calculation implies to invest in replacement of existing overhead distribution system by underground distribution system

and finally which can be payback after 6 to 7 year of replacement.

REFERENCES

1. IEEE Standard. IEEE Guide for Electric Power Distribution Reliability Indices. IEEE Power & Energy Society. 2012.
2. Allan RN, Billinton R, Sjarief I, Goel L, So KS. A reliability test system for educational purposes-basic distribution system data and results. IEEE Transactions on Power systems. 1991 May;6(2):813-20.
3. NEA. Substation Record File [Internet]. Nepal Electricity Authority. Available from: www.nea.org.np
4. IEEE Standard Association. Historical Reliability Data for IEEE 3006 Standards: Power Systems Reliability. IEEE 3000 Standards Collection - IEEE 3006 Standards: Power System Reliability. 2012; 1–303.
5. NEA. NEA Underground Contract Document [Internet]. Nepal Electricity Authority. Available from: www.nea.org.np